



Most Widely Accepted and Trusted

# ICC-ES Report

## ESR-3187

ICC-ES | (800) 423-6587 | (562) 699-0543 | www.icc-es.org

Reissued 03/2014  
This report is subject to renewal 03/2016.

**DIVISION: 03 00 00—CONCRETE**  
**SECTION: 03 16 00—CONCRETE ANCHORS**  
**DIVISION: 05 00 00—METALS**  
**SECTION: 05 05 19—POST-INSTALLED CONCRETE ANCHORS**

**REPORT HOLDER:**

**HILTI, INC.**

**7250 DALLAS PARKWAY, SUITE 1000  
PLANO, TEXAS 75024**

**EVALUATION SUBJECT:**

**HILTI HIT-HY 200 ADHESIVE ANCHORS AND POST INSTALLED REINFORCING BAR  
CONNECTIONS IN CONCRETE**



Look for the trusted marks of Conformity!

*“2014 Recipient of Prestigious Western States Seismic Policy Council (WSSPC) Award in Excellence”*



A Subsidiary of

*ICC-ES Evaluation Reports are not to be construed as representing aesthetics or any other attributes not specifically addressed, nor are they to be construed as an endorsement of the subject of the report or a recommendation for its use. There is no warranty by ICC Evaluation Service, LLC, express or implied, as to any finding or other matter in this report, or as to any product covered by the report.*



**ICC-ES Evaluation Report****ESR-3187\***

Reissued March 2014

This report is subject to renewal March 2016.

[www.icc-es.org](http://www.icc-es.org) | (800) 423-6587 | (562) 699-0543

A Subsidiary of the International Code Council®

**DIVISION: 03 00 00—CONCRETE**  
**Section: 03 16 00—Concrete Anchors****DIVISION: 05 00 00—METALS**  
**Section: 05 05 19—Post-installed Concrete Anchors****REPORT HOLDER:****HILTI, INC.**  
7250 DALLAS PARKWAY, SUITE 1000  
PLANO, TEXAS 75024  
(800) 879-8000  
[www.us.hilti.com](http://www.us.hilti.com)  
[HiltiTechEng@us.hilti.com](mailto:HiltiTechEng@us.hilti.com)**EVALUATION SUBJECT:****HILTI HIT-HY 200 ADHESIVE ANCHORS AND POST  
INSTALLED REINFORCING BAR CONNECTIONS IN  
CONCRETE****1.0 EVALUATION SCOPE****Compliance with the following codes:**

- 2012, 2009 and 2006 *International Building Code*® (IBC)
- 2012, 2009 and 2006 *International Residential Code*® (IRC)

**Property evaluated:**

Structural

**2.0 USES**

The Hilti HIT-HY 200 Adhesive Anchoring System and Post-Installed Reinforcing Bar System are used to resist static, wind and earthquake (Seismic Design Categories A through F) tension and shear loads in cracked and uncracked normal-weight concrete having a specified compressive strength,  $f'_c$ , of 2,500 psi to 8,500 psi (17.2 MPa to 58.6 MPa).

The anchor system complies with anchors as described in Section 1909 of the 2012 IBC and is an alternative to cast-in-place anchors described in Section 1908 of the 2012 IBC, and Sections 1911 and 1912 of the 2009 and 2006 IBC. The anchor systems may also be used where an engineered design is submitted in accordance with Section R301.1.3 of the IRC.

The post-installed reinforcing bar system is an alternative to cast-in-place reinforcing bars governed by ACI 318 and IBC Chapter 19.

**3.0 DESCRIPTION****3.1 General:**

The Hilti HIT-HY 200 Adhesive Anchoring System and Post-Installed Reinforcing Bar System are comprised of the following components:

- Hilti HIT-HY 200 adhesive packaged in foil packs (either Hilti HIT-HY 200-A or Hilti HIT-HY 200-R)
- Adhesive mixing and dispensing equipment
- Equipment for hole cleaning and adhesive injection

The Hilti HIT-HY 200 Adhesive Anchoring System may be used with continuously threaded rod, Hilti HIT-Z(-R) anchor rods, Hilti HIS-(R)N internally threaded inserts or deformed steel reinforcing bars as depicted in Figure 1. The Hilti HIT-HY 200 Post-Installed Reinforcing Bar System may only be used with deformed steel reinforcing bars as depicted in Figure 2. The primary components of the Hilti Adhesive Anchoring and Post-Installed Reinforcing Bar Systems, including the Hilti HIT-HY 200 Adhesive, HIT-RE-M static mixing nozzle and steel anchoring elements, are shown in Figure 6 of this report.

The manufacturer's printed Installation instructions (MPII), as included with each adhesive unit package, are replicated as Figure 9.

**3.2 Materials:**

**3.2.1 Hilti HIT-HY 200 Adhesive:** Hilti HIT-HY 200 Adhesive is an injectable, two-component hybrid adhesive. The two components are separated by means of a dual-cylinder foil pack attached to a manifold. The two components combine and react when dispensed through a static mixing nozzle attached to the manifold. Hilti HIT-HY 200 is available in 11.1-ounce (330 mL) and 16.9-ounce (500 mL) foil packs. The manifold attached to each foil pack is stamped with the adhesive expiration date. The shelf life, as indicated by the expiration date, applies to an unopened foil pack stored in a dry, dark environment and in accordance with Figure 9.

Hilti HIT-HY 200 Adhesive is available in two options, Hilti HIT-HY 200-A and Hilti HIT-HY 200-R. Both options are subject to the same technical data as set forth in this report. Hilti HIT-HY 200-A will have shorter working times and curing times than Hilti HIT-HY 200-R. The packaging for each option employs a different color, which helps the user distinguish between the two adhesives.

**3.2.2 Hole Cleaning Equipment:**

**3.2.2.1 Standard Equipment:** Standard hole cleaning equipment, comprised of steel wire brushes and air nozzles, is described in Figure 9 of this report.

**\*Revised July 2015**

**3.2.2.2 Hilti Safe-Set™ System:** The Hilti Safe-Set™ with Hilti HIT-HY 200 consists of one of the following:

- For the Hilti HIT-Z and HIT-Z-R anchor rods, hole cleaning is not required after drilling the hole, except if the hole is drilled with a diamond core drill bit.
- For the elements described in Sections 3.2.4.2 through 3.2.4.4 and Section 3.2.5, the Hilti TE-CD or TE-YD hollow carbide drill bit with a carbide drilling head conforming to ANSI B212.15. Used in conjunction with a Hilti VC 20/40 vacuum, the Hilti TE-CD or TE-YD drill bit will remove the drilling dust, automatically cleaning the hole.

**3.2.3 Dispensers:** Hilti HIT-HY 200 must be dispensed with manual or electric dispensers provided by Hilti.

### 3.2.4 Anchor Elements:

**3.2.4.1 Hilti HIT-Z and HIT-Z-R Anchor Rods:** Hilti HIT-Z and HIT-Z-R anchor rods have a conical shape on the embedded section and a threaded section above the concrete surface. Mechanical properties for the Hilti HIT-Z and HIT-Z-R anchor rods are provided in Table 2. The rods are available in diameters as shown in Table 7 and Figure 1. Hilti HIT-Z anchor rods are produced from carbon steel and furnished with a 0.005-millimeter-thick (5  $\mu\text{m}$ ) zinc electroplated coating. Hilti HIT-Z-R anchor rods are fabricated from grade 316 stainless steel.

**3.2.4.2 Threaded Steel Rods:** Threaded steel rods must be clean, continuously threaded rods (all-thread) in diameters as described in Tables 11 and 15 and Figure 1 of this report. Steel design information for common grades of threaded rods is provided in Table 3. Carbon steel threaded rods must be furnished with a 0.0002-inch-thick (0.005 mm) zinc electroplated coating complying with ASTM B633 SC 1 or must be hot-dipped galvanized complying with ASTM A153, Class C or D. Stainless steel threaded rods must comply with ASTM F593 or ISO 3506 A4. Threaded steel rods must be straight and free of indentations or other defects along their length. The ends may be stamped with identifying marks and the embedded end may be blunt cut or cut on the bias to a chisel point.

**3.2.4.3 Steel Reinforcing Bars for use in Post-Installed Anchor Applications:** Steel reinforcing bars are deformed bars as described in Table 4 of this report. Tables 11, 15, and 19 and Figure 1 summarize reinforcing bar size ranges. The embedded portions of reinforcing bars must be straight, and free of mill scale, rust, mud, oil and other coatings (other than zinc) that may impair the bond with the adhesive. Reinforcing bars must not be bent after installation except as set forth in Section 7.3.2 of ACI 318-11, with the additional condition that the bars must be bent cold, and heating of reinforcing bars to facilitate field bending is not permitted.

**3.2.4.4 Hilti HIS-N and HIS-RN Inserts:** Hilti HIS-N and HIS-RN inserts have a profile on the external surface and are internally threaded. Mechanical properties for Hilti HIS-N and HIS-RN inserts are provided in Table 5. The inserts are available in diameters and lengths as shown in Table 22 and Figure 1. Hilti HIS-N inserts are produced from carbon steel and furnished with a 0.005-millimeter-thick (5  $\mu\text{m}$ ) zinc electroplated coating complying with ASTM B633 SC 1. The stainless steel Hilti HIS-RN inserts are fabricated from X5CrNiMo17122 K700 steel conforming to DIN 17440. Specifications for common bolt types that may be used in conjunction with Hilti HIS-N and HIS-RN inserts are provided in Table 6. Bolt grade and material type (carbon, stainless) must be matched to the insert. Strength reduction factors,  $\phi$ , corresponding to brittle steel elements must be used for Hilti HIS-N and HIS-RN inserts.

**3.2.4.5 Ductility:** In accordance with ACI 318-11 D.1, in order for a steel element to be considered ductile, the tested elongation must be at least 14 percent and reduction of area must be at least 30 percent. Steel elements with a tested elongation of less than 14 percent or a reduction of area of less than 30 percent, or both, are considered brittle. Values for various steel materials are provided in Tables 2, 3, and 6 of this report. Where values are nonconforming or unstated, the steel must be considered brittle.

### 3.2.5 Steel Reinforcing Bars for Use in Post-Installed Reinforcing Bar Connections:

Steel reinforcing bars used in post-installed reinforcing bar connections are deformed bars (rebar) as depicted in Figures 2 and 3. Tables 25, 26, 27, and Figure 9 summarize reinforcing bar size ranges. The embedded portions of reinforcing bars must be straight, and free of mill scale, rust and other coatings that may impair the bond with the adhesive. Reinforcing bars must not be bent after installation, except as set forth in Section 7.3.2 of ACI 318-11 with the additional condition that the bars must be bent cold, and heating of reinforcing bars to facilitate field bending is not permitted.

### 3.3 Concrete:

Normal-weight concrete must comply with Sections 1903 and 1905 of the IBC, as applicable. The specified compressive strength of the concrete must be from 2,500 psi to 8,500 psi (17.2 MPa to 58.6 MPa).

## 4.0 DESIGN AND INSTALLATION

### 4.1 Strength Design of Post-Installed Anchors:

Refer to Table 1 for the design parameters for specific installed elements, and refer to Figure 4 and Section 4.1.4 for a flowchart to determine the applicable design bond strength or pullout strength.

**4.1.1 General:** The design strength of anchors under the 2012, 2009 and 2006 IBC, as well as the 2012, 2009 and 2006 IRC must be determined in accordance with ACI 318-11 (ACI 318) and this report.

A design example according to the 2012 IBC based on ACI 318-11 is given in Figure 7 of this report.

Design parameters are based on ACI 318-11 for use with the 2012, 2009 and 2006 IBC unless noted otherwise in Sections 4.1.1 through 4.1.11 of this report.

The strength design of anchors must comply with ACI 318-11 D.4.1, except as required in ACI 318-11 D.3.3.

Design parameters, are provided in Table 7 through Table 24. Strength reduction factors,  $\phi$ , as given in ACI 318-11 D.4.3 must be used for load combinations calculated in accordance with Section 1605.2 of the 2012, 2009 or 2006 IBC or Section 9.2 of ACI 318-11. Strength reduction factors,  $\phi$ , as given in ACI 318-11 D.4.4 must be used for load combinations calculated in accordance with ACI 318-11 Appendix C.

**4.1.2 Static Steel Strength in Tension:** The nominal static steel strength of a single anchor in tension,  $N_{sa}$ , in accordance with ACI 318-11 Section D.5.1.2 and the associated strength reduction factors,  $\phi$ , in accordance with ACI 318-11 Section D.4.3, are provided in the tables outlined in Table 1 for the anchor element types included in this report.

**4.1.3 Static Concrete Breakout Strength in Tension:** The nominal concrete breakout strength of a single anchor or group of anchors in tension,  $N_{cb}$  or  $N_{cbg}$ , must be calculated in accordance with ACI 318-11 D.5.2 with the following addition:

The basic concrete breakout strength of a single anchor in tension,  $N_b$ , must be calculated in accordance with ACI 318-11 D.5.2.2 using the values of  $k_{c,cr}$  and  $k_{c,uncr}$  as described in this report. Where analysis indicates no cracking in accordance with ACI 318-11 D.5.2.6,  $N_b$  must be calculated using  $k_{c,uncr}$  and  $\Psi_{c,N} = 1.0$ . See Table 1. For anchors in lightweight concrete, see ACI 318-11 D.3.6. The value of  $f'_c$  used for calculation must be limited to 8,000 psi (55 MPa) in accordance with ACI 318-11 D.3.7. Additional information for the determination of nominal bond strength in tension is given in Section 4.1.4 of this report.

**4.1.4 Static Bond Strength/Static Pullout Strength in Tension:**

**4.1.4.1 Static Pullout Strength in Tension: Hilti HIT-Z and HIT-Z-R Anchor Rods:** The nominal static pullout strength of a single anchor in accordance with ACI 318-11 D.5.3.1 and D.5.3.2 in cracked and uncracked concrete,  $N_{p,cr}$  and  $N_{p,uncr}$ , respectively, is given in Table 10. For all design cases  $\Psi_{c,P} = 1.0$ .

Pullout strength values are a function of the concrete compressive strength, whether the concrete is cracked or uncracked, the drilling method (hammer drill, including Hilti hollow drill bit, diamond core drill) and installation conditions (dry or water-saturated). The resulting characteristic pullout strength must be multiplied by the associated strength reduction factor  $\phi_{nn}$  as follows:

HILTI HIT-Z AND HIT-Z-R THREADED RODS				
DRILLING METHOD	CONCRETE TYPE	PERMISSIBLE INSTALLATION CONDITIONS	PULLOUT STRENGTH	ASSOCIATED STRENGTH REDUCTION FACTOR
Hammer-drill (or Hilti TE-CD or TE-YD Hollow Drill Bit) or Diamond Core Bit	Uncracked	Dry	$N_{p,uncr}$	$\phi_d$
		Water saturated	$N_{p,uncr}$	$\phi_{ws}$
	Cracked	Dry	$N_{p,cr}$	$\phi_d$
		Water saturated	$N_{p,cr}$	$\phi_{ws}$

Figure 4 of this report presents a pullout strength design selection flowchart. Strength reduction factors for determination of the bond strength are given in the tables referenced in Table 1 of this report.

**4.1.4.2 Static Bond Strength in Tension: Threaded Rod, Steel Reinforcing Bars, and Hilti HIS-N and HIS-RN Inserts:** The nominal static bond strength of a single adhesive anchor or group of adhesive anchors in tension,  $N_a$  or  $N_{ag}$ , must be calculated in accordance with ACI 318-11 D.5.5. Bond strength values are a function of the concrete compressive strength, whether the concrete is cracked or uncracked, the concrete temperature range, and the installation conditions (dry or water-saturated concrete). The resulting characteristic bond strength shall be multiplied by the associated strength reduction factor  $\phi_{nn}$  as follows:

DRILLING METHOD	CONCRETE TYPE	PERMISSIBLE INSTALLATION CONDITIONS	BOND STRENGTH	ASSOCIATED STRENGTH REDUCTION FACTOR
Hammer-drill (or Hilti TE-CD or TE-YD Hollow Drill Bit)	Uncracked	Dry	$\tau_{k,uncr}$	$\phi_d$
		Water saturated	$\tau_{k,uncr}$	$\phi_{ws}$
	Cracked	Dry	$\tau_{k,cr}$	$\phi_d$
		Water saturated	$\tau_{k,cr}$	$\phi_{ws}$

Figure 4 of this report presents a bond strength design selection flowchart. Strength reduction factors for determination of the bond strength are outlined in Table 1 of this report. Adjustments to the bond strength may also

be made for increased concrete compressive strength as noted in the footnotes to the bond strength tables.

**4.1.5 Static Steel Strength in Shear:** The nominal static strength of a single anchor in shear as governed by the steel,  $V_{sa}$ , in accordance with ACI 318-11 D.6.1.2 and strength reduction factors,  $\phi$ , in accordance with ACI 318-11 D.4.3 are given in the tables outlined in Table 1 for the anchor element types included in this report.

**4.1.6 Static Concrete Breakout Strength in Shear:** The nominal static concrete breakout strength of a single anchor or group of anchors in shear,  $V_{cb}$  or  $V_{cbg}$ , must be calculated in accordance with ACI 318-11 D.6.2 based on information given in the tables outlined in Table 1. The basic concrete breakout strength of a single anchor in shear,  $V_b$ , must be calculated in accordance with ACI 318-11 D.6.2.2 using the values of  $d$  given in the tables as outlined in Table 1 for the corresponding anchor steel in lieu of  $d_a$  (2012 and 2009 IBC) and  $d_o$  (2006 IBC). In addition,  $h_{ef}$  must be substituted for  $\ell_e$ . In no case must  $\ell_e$  exceed  $8d$ . The value of  $f'_c$  must be limited to a maximum of 8,000 psi (55 MPa) in accordance with ACI 318-11 D.3.7.

**4.1.7 Static Concrete Pryout Strength in Shear:** The nominal static pryout strength of a single anchor or group of anchors in shear,  $V_{cp}$  or  $V_{cpg}$ , must be calculated in accordance with ACI 318-11 D.6.3.

**4.1.8 Interaction of Tensile and Shear Forces:** For designs that include combined tension and shear, the interaction of tension and shear loads must be calculated in accordance with ACI 318-11 Section D.7.

**4.1.9 Minimum Member Thickness,  $h_{min}$ , Anchor Spacing,  $s_{min}$  and Edge Distance,  $c_{min}$ :**

**4.1.9.1 Hilti HIT-Z and HIT-Z-R Anchor Rods:** In lieu of ACI 318-11 D.8.1 and D.8.3, values of  $s_{min}$  and  $c_{min}$  described in Table 9 of this report must be observed for anchor design and installation. The minimum member thicknesses,  $h_{min}$ , given in Table 9 of this report must be observed for anchor design and installation.

**4.1.9.2 Threaded Rod, Steel Reinforcing Bars, and Hilti HIS-N and HIS-RN Inserts:** In lieu of ACI 318-11 D.8.1 and D.8.3, values of  $c_{min}$  and  $s_{min}$  described in this report must be observed for anchor design and installation. Likewise, in lieu of ACI 318-11 D.8.5, the minimum member thicknesses,  $h_{min}$ , described in this report must be observed for anchor design and installation. For adhesive anchors that will remain untorqued, ACI 318-11 D.8.4 applies.

For edge distances  $c_{ai}$  and anchor spacing  $s_{ai}$ , the maximum torque  $T_{max}$  shall comply with the following requirements:

REDUCED MAXIMUM INSTALLATION TORQUE $T_{max,red}$ FOR EDGE DISTANCES $c_{ai} < (5 \times d_a)$		
EDGE DISTANCE, $c_{ai}$	MINIMUM ANCHOR SPACING, $s_{ai}$	MAXIMUM TORQUE, $T_{max,red}$
1.75 in. (45 mm) $\leq c_{ai} < 5 \times d_a$	$5 \times d_a \leq s_{ai} < 16$ in.	$0.3 \times T_{max}$
	$s_{ai} \geq 16$ in. (406 mm)	$0.5 \times T_{max}$

**4.1.10 Critical Edge Distance  $c_{ac}$ :**

**4.1.10.1 Hilti HIT-Z and HIT-Z-R Anchor Rods:** In lieu of ACI 318-11 D.8.6, for the calculation of  $N_{cb}$  and  $N_{cbg}$  in accordance with D.5.2.7 and Section 4.1.3 of this report, the critical edge distance,  $c_{ac}$ , must be determined as follows:

- i.  $c_{ac} = 1.5 \cdot h_{ef}$  for  $h/h_{ef} \geq 2.35$
- ii.  $c_{ac} = 3.5 \cdot h_{ef}$  for  $h/h_{ef} \leq 1.35$

For definitions of  $h$  and  $h_{ef}$ , see Figure 1.

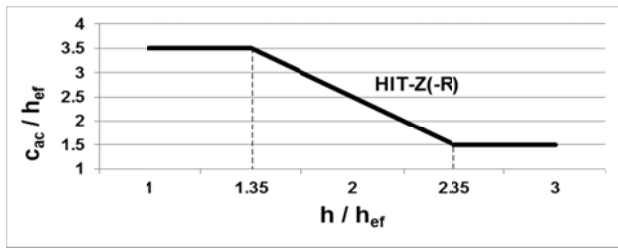

Linear interpolation is permitted to determine the ratio of  $c_{ac}/h_{ef}$  for values of  $h/h_{ef}$  between 2.35 and 1.35 as illustrated in the graph above.

**4.1.10.2 Threaded Rod, Steel Reinforcing Bars, and Hilti HIS-N and HIS-RN Inserts:** In lieu of ACI 318-11 D.8.6,  $c_{ac}$  must be determined as follows:

$$c_{ac} = h_{ef} \cdot \left( \frac{\tau_{k,uncr}}{1160} \right)^{0.4} \cdot \max \left[ 3.1 - 0.7 \frac{h}{h_{ef}}; 1.4 \right] \quad \text{Eq. (4-1)}$$

where  $\tau_{k,uncr}$  is the characteristic bond strength in uncracked concrete,  $h$  is the member thickness, and  $h_{ef}$  is the embedment depth.

$\tau_{k,uncr}$  need not be taken as greater than:

$$\tau_{k,uncr} = \frac{k_{uncr} \sqrt{h_{ef} f_c'}}{\pi \cdot d}$$

**4.1.11 Design Strength in Seismic Design Categories C, D, E and F:** In structures assigned to Seismic Design Category C, D, E or F under the IBC or IRC, the design must be performed according to ACI 318-11 Section D.3.3 The nominal steel shear strength,  $V_{sa}$ , must be adjusted by  $\alpha_{V,seis}$  as given in the tables summarized in Table 1 for the anchor element types included in this report. For tension, the nominal pullout strength  $N_{p,cr}$  or bond strength  $\tau_{cr}$  must be adjusted by  $\alpha_{N,seis}$ . See Tables 10, 13, 14, 17, 18, 21 and 24.

Modify ACI 318-11 Sections D.3.3.4.2, D.3.3.4.3(d) and D.3.3.5.2 to read as follows:

D.3.3.4.2 - Where the tensile component of the strength-level earthquake force applied to anchors exceeds 20 percent of the total factored anchor tensile force associated with the same load combination, anchors and their attachments shall be designed in accordance with D.3.3.4.3. The anchor design tensile strength shall be determined in accordance with D.3.3.4.4

**Exception:**

1. Anchors designed to resist wall out-of-plane forces with design strengths equal to or greater than the force determined in accordance with ASCE 7 Equation 12.11-1 or 12.14-10 shall be deemed to satisfy Section D.3.3.4.3(d).

D.3.3.4.3(d) – The anchor or group of anchors shall be designed for the maximum tension obtained from design load combinations that include E, with E increased by  $\Omega_0$ . The anchor design tensile strength shall be calculated from D.3.3.4.4.

D.3.3.5.2 – Where the shear component of the strength-level earthquake force applied to anchors exceeds 20 percent of the total factored anchor shear force associated with the same load combination, anchors and their attachments shall be designed in accordance with D.3.3.5.3. The anchor design shear strength for resisting earthquake forces shall be determined in accordance with D.6.

**Exceptions:**

1. For the calculation of the in-plane shear strength of anchor bolts attaching wood sill plates of bearing or non-bearing walls of light-frame wood structures to foundations or foundation stem walls, the in-plane shear strength in accordance with D.6.2 and D.6.3 need not be computed and D.3.3.5.3 need not apply provided all of the following are satisfied:

- 1.1. The allowable in-plane shear strength of the anchor is determined in accordance with AF&PA NDS Table 11E for lateral design values parallel to grain.
- 1.2. The maximum anchor nominal diameter is  $5/8$  inch (16 mm).
- 1.3. Anchor bolts are embedded into concrete a minimum of 7 inches (178 mm).
- 1.4. Anchor bolts are located a minimum of  $1\ 3/4$  inches (45 mm) from the edge of the concrete parallel to the length of the wood sill plate.
- 1.5. Anchor bolts are located a minimum of 15 anchor diameters from the edge of the concrete perpendicular to the length of the wood sill plate.
- 1.6. The sill plate is 2-inch or 3-inch nominal thickness.

2. For the calculation of the in-plane shear strength of anchor bolts attaching cold-formed steel track of bearing or non-bearing walls of light-frame construction to foundations or foundation stem walls, the in-plane shear strength in accordance with D.6.2 and D.6.3 need not be computed and D.3.3.5.3 need not apply provided all of the following are satisfied:

- 2.1. The maximum anchor nominal diameter is  $5/8$  inch (16 mm).
- 2.2. Anchors are embedded into concrete a minimum of 7 inches (178 mm).
- 2.3. Anchors are located a minimum of  $1\ 3/4$  inches (45 mm) from the edge of the concrete parallel to the length of the track.
- 2.4. Anchors are located a minimum of 15 anchor diameters from the edge of the concrete perpendicular to the length of the track.
- 2.5. The track is 33 to 68 mil designation thickness.

Allowable in-plane shear strength of exempt anchors, parallel to the edge of concrete shall be permitted to be determined in accordance with AISI S100 Section E3.3.1.

3. In light-frame construction, bearing or nonbearing walls, shear strength of concrete anchors less than or equal to 1 inch [25 mm] in diameter attaching a sill plate or track to foundation or foundation stem wall need not satisfy D.3.3.5.3(a) through (c) when the design strength of the anchors is determined in accordance with D.6.2.1(c).

**4.2 Strength Design of Post-Installed Reinforcing Bars:**

**4.2.1 General:** The design of straight post-installed deformed reinforcing bars must be determined in accordance with ACI 318-11 (ACI 318) rules for cast-in place reinforcing bar development and splices and this report.

Examples of typical applications for the use of post-installed reinforcing bars are illustrated in Figure 3 of this report.

A design example in accordance with the 2012 IBC based on ACI 318-11 is given in Figure 8 of this report.

**4.2.2 Determination of bar development length  $l_d$ :** Values of  $l_d$  must be determined in accordance with the ACI 318-11 development and splice length requirements for straight cast-in place reinforcing bars.

**Exceptions:**

1. For uncoated and zinc-coated (galvanized) post-installed reinforcing bars, the factor  $\Psi_e$  shall be taken as 1.0. For all other cases, the requirements in ACI 318-11 Section 12.2.4 (b) shall apply.
2. When using alternate methods to calculate the development length (e.g., anchor theory), the applicable factors for post-installed anchors generally apply.

**4.2.3 Minimum Member Thickness,  $h_{min}$ , Minimum Concrete Cover,  $c_{c,min}$ , Minimum Concrete Edge Distance,  $c_{b,min}$ , Minimum Spacing,  $s_{b,min}$ :** For post-installed reinforcing bars, there is no limit on the minimum member thickness. In general, all requirements on concrete cover and spacing applicable to straight cast-in bars designed in accordance with ACI 318-11 shall be maintained.

For post-installed reinforcing bars installed at embedment depths,  $h_{ef}$ , larger than  $20d$  ( $h_{ef} > 20d$ ), the minimum concrete cover shall be as follows:

REBAR SIZE	MINIMUM CONCRETE COVER, $c_{c,min}$
$d_b \leq \text{No. 6 (16mm)}$	$1^{3/16} \text{ in. (30mm)}$
$\text{No. 6} < d_b \leq \text{No. 10 (16mm} < d_b \leq 32\text{mm)}$	$1^{9/16} \text{ in. (40mm)}$

The following requirements apply for minimum concrete edge and spacing for  $h_{ef} > 20d$ :

Required minimum edge distance for post-installed reinforcing bars (measured from the center of the bar):

$$c_{b,min} = d_0/2 + c_{c,min}$$

Required minimum center-to-center spacing between post-installed bars:

$$s_{b,min} = d_0 + c_{c,min}$$

Required minimum center-to-center spacing from existing (parallel) reinforcing:

$$s_{b,min} = d_b/2 \text{ (existing reinforcing)} + d_0/2 + c_{c,min}$$

**4.2.4 Design Strength in Seismic Design Categories C, D, E and F:** In structures assigned to Seismic Category C, D, E or F under the IBC or IRC, design of straight post-installed reinforcing bars must take into account the provisions of ACI 318-11 Chapter 21. The value of  $f'_c$  to be used in ACI 318-11 Section 12.2.2, 12.2.3, and 12.3.2 calculations shall not exceed 2,500 psi for post-installed reinforcing bar applications in SDCs C, D, E, and F.

**4.3 Installation:**

Installation parameters are illustrated in Figure 1. Installation must be in accordance with ACI 318-11 D.9.1 and D.9.2. Anchor and post-installed reinforcing bar locations must comply with this report and the plans and specifications approved by the code official. Installation of the Hilti HIT-HY 200 Adhesive Anchor and Post-Installed Reinforcing Bar Systems must conform to the manufacturer's printed installation instructions (MPII) included in each unit package as provided in Figure 9 of this report. The MPII contains additional requirements for combinations of drill hole depth, diameter, drill bit type, and dispensing tools.

**4.4 Special Inspection:**

Periodic special inspection must be performed where required in accordance with Section 1705.1.1 and Table

1705.3 of the 2012 IBC, Sections 1704.4 and 1704.15 of the 2009 IBC, or Section 1704.13 of the 2006 IBC, and this report. The special inspector must be on the jobsite initially during anchor or post-installed reinforcing bar installation to verify anchor or post-installed reinforcing bar type and dimensions, concrete type, concrete compressive strength, adhesive identification and expiration date, hole dimensions, hole cleaning procedures, spacing, edge distances, concrete thickness, anchor or post-installed reinforcing bar embedment, tightening torque and adherence to the manufacturer's printed installation instructions.

The special inspector must verify the initial installations of each type and size of adhesive anchor or post-installed reinforcing bar by construction personnel on site. Subsequent installations of the same anchor or post-installed reinforcing bar type and size by the same construction personnel are permitted to be performed in the absence of the special inspector. Any change in the anchor or post-installed reinforcing bar product being installed or the personnel performing the installation requires an initial inspection. For ongoing installations over an extended period, the special inspector must make regular inspections to confirm correct handling and installation of the product.

Continuous special inspection of adhesive anchors or post-installed reinforcing bar installed in horizontal or upwardly inclined orientations to resist sustained tension loads shall be performed in accordance with ACI 318-11 D.9.2.4.

Under the IBC, additional requirements as set forth in Sections 1705, 1706, and 1707 must be observed, where applicable.

**5.0 CONDITIONS OF USE**

The Hilti HIT-HY 200 Adhesive Anchor System and Post-Installed Reinforcing Bar System described in this report complies with or is a suitable alternative to what is specified in the codes listed in Section 1.0 of this report, subject to the following conditions:

- 5.1 Hilti HIT-HY 200 Adhesive anchors and post-installed reinforcing bars must be installed in accordance with the manufacturer's printed installation instructions (MPII) as included in the adhesive packaging and provided in Figure 9 of this report.
- 5.2 The anchors and post-installed reinforcing bars must be installed in cracked and uncracked normal-weight concrete having a specified compressive strength  $f'_c = 2,500 \text{ psi to } 8,500 \text{ psi (17.2 MPa to } 58.6 \text{ MPa)}$ .
- 5.3 The values of  $f'_c$  used for calculation purposes must not exceed 8,000 psi (55.1 MPa) except as noted in Sections 4.2.2 and 4.2.4 of this report.
- 5.4 Anchors and post-installed reinforcing bars must be installed in concrete base materials in holes predrilled in accordance with the instructions in Figure 9, using carbide-tipped masonry drill bits manufactured with the range of maximum and minimum drill-tip dimensions specified in ANSI B212.15-1994. The Hilti HIT-Z(-R) anchor rods may be installed in holes predrilled using diamond core drill bits.
- 5.5 Loads applied to the anchors must be adjusted in accordance with Section 1605.2 of the IBC for strength design.
- 5.6 Hilti HIT-HY 200 adhesive anchors and post-installed reinforcing bars are recognized for use to resist short- and long-term loads, including wind and earthquake, subject to the conditions of this report.

- 5.7 In structures assigned to Seismic Design Category C, D, E or F under the IBC or IRC, anchor strength must be adjusted in accordance with Section 4.1.11 of this report, and post-installed reinforcing bars must comply with section 4.2.4 of this report.
- 5.8 Hilti HIT-HY 200 adhesive anchors and post-installed reinforcing bars are permitted to be installed in concrete that is cracked or that may be expected to crack during the service life of the anchor, subject to the conditions of this report.
- 5.9 Anchor strength design values must be established in accordance with Section 4.1 of this report.
- 5.10 Post-installed reinforcing bar development and splice length is established in accordance with Section 4.2 of this report.
- 5.11 Minimum anchor spacing and edge distance as well as minimum member thickness must comply with the values noted in this report.
- 5.12 Post-installed reinforcing bar spacing, minimum member thickness, and cover distance must be in accordance with the provisions of ACI 318-11 for cast-in place bars and section 4.2.3 of this report.
- 5.13 Prior to anchor installation, calculations and details demonstrating compliance with this report must be submitted to the code official. The calculations and details must be prepared by a registered design professional where required by the statutes of the jurisdiction in which the project is to be constructed.
- 5.14 Anchors and post-installed reinforcing bars are not permitted to support fire-resistive construction. Where not otherwise prohibited by the code, Hilti HIT-HY 200 adhesive anchors and post-installed reinforcing bars are permitted for installation in fire-resistive construction provided that at least one of the following conditions is fulfilled:
- Anchors and post-installed reinforcing bars are used to resist wind or seismic forces only.
  - Anchors and post-installed reinforcing bars that support gravity load-bearing structural elements are within a fire-resistive envelope or a fire-resistive membrane, are protected by approved fire-resistive materials, or have been evaluated for resistance to fire exposure in accordance with recognized standards.
  - Anchors and post-installed reinforcing bars are used to support nonstructural elements.
- 5.15 Since an ICC-ES acceptance criteria for evaluating data to determine the performance of adhesive anchors and post-installed reinforcing bars subjected to fatigue or shock loading is unavailable at this time, the use of these anchors under such conditions is beyond the scope of this report.
- 5.16 Use of zinc-plated carbon steel threaded rods or steel reinforcing bars is limited to dry, interior locations.
- 5.17 Use of hot-dipped galvanized carbon steel and stainless steel rods is permitted for exterior exposure or damp environments.
- 5.18 Steel anchoring materials in contact with preservative-treated and fire-retardant-treated wood must be of zinc-coated carbon steel or stainless steel. The minimum coating weights for zinc-coated steel must comply with ASTM A153.
- 5.19 Periodic special inspection must be provided in accordance with Section 4.4 of this report. Continuous special inspection for anchors and post-installed reinforcing bars installed in horizontal or upwardly inclined orientations to resist sustained tension loads must be provided in accordance with Section 4.4 of this report.
- 5.20 Installation of anchors and post-installed reinforcing bars in horizontal or upwardly inclined orientations to resist sustained tension loads shall be performed by personnel certified by an applicable certification program in accordance with ACI 318-11 D.9.2.2 or D.9.2.3.
- 5.21 Hilti HIT-HY 200-A adhesive anchors and post-installed reinforcing bars may be used to resist tension and shear forces in floor, wall, and overhead installations only if installation is into concrete with a temperature between 14°F and 104°F (-10°C and 40°C) for threaded rods, rebar, and Hilti HIS-(R)N inserts, or between 41°F and 104°F (5°C and 40°C) for Hilti HIT-Z(-R) anchor rods. Overhead installations require the use of piston plugs (HIT-SZ, -IP) during injection, and the anchor or post-installed reinforcing bars must be supported until fully cured (i.e., with Hilti HIT-OHW wedges, or other suitable means). Installations in concrete temperatures below 32°F require the adhesive to be conditioned to a minimum temperature of 32°F.
- 5.22 Anchors and post-installed reinforcing bars shall not be used for applications where the concrete temperature can rise from 40°F or less to 80°F or higher within a 12-hour period. Such applications may include but are not limited to anchorage of building facade systems and other applications subject to direct sun exposure.
- 5.23 Hilti HIT-HY 200-A and Hilti HIT-HY 200-R adhesives are manufactured by Hilti GmbH, Kaufering, Germany, under a quality control program with inspections by ICC-ES.
- 5.24 Hilti HIT-Z and HIT-Z-R rods are manufactured by Hilti AG, Schaan, Liechtenstein, under a quality-control program with inspections by ICC-ES.
- 5.25 Hilti HIS-N and HIS-RN inserts are manufactured by Hilti (China) Ltd., Guangdong, China, under a quality-control program with inspections by ICC-ES.
- ## 6.0 EVIDENCE SUBMITTED
- Data in accordance with the ICC-ES Acceptance Criteria for Post-installed Adhesive Anchors in Concrete (AC308), dated February 2015, which incorporates requirements in ACI 355.4-11, and Table 3.8 for evaluating post-installed reinforcing bars.
- ## 7.0 IDENTIFICATION
- 7.1 Hilti HIT-HY 200-A and Hilti HIT-HY 200-R adhesive is identified by packaging labeled with the manufacturer's name (Hilti Corp.) and address, product name, lot number, expiration date, and evaluation report number (ESR-3187).
- 7.2 Hilti HIT-Z and HIT-Z-R rods are identified by packaging labeled with the manufacturer's name (Hilti Corp.) and address, anchor name, and evaluation report number (ESR-3187).
- 7.3 Hilti HIS-N and HIS-RN inserts are identified by packaging labeled with the manufacturer's name (Hilti Corp.) and address, anchor name and size, and evaluation report number (ESR-3187).
- 7.4 Threaded rods, nuts, washers, bolts, cap screws, and deformed reinforcing bars are standard elements and must conform to applicable national or international specifications.

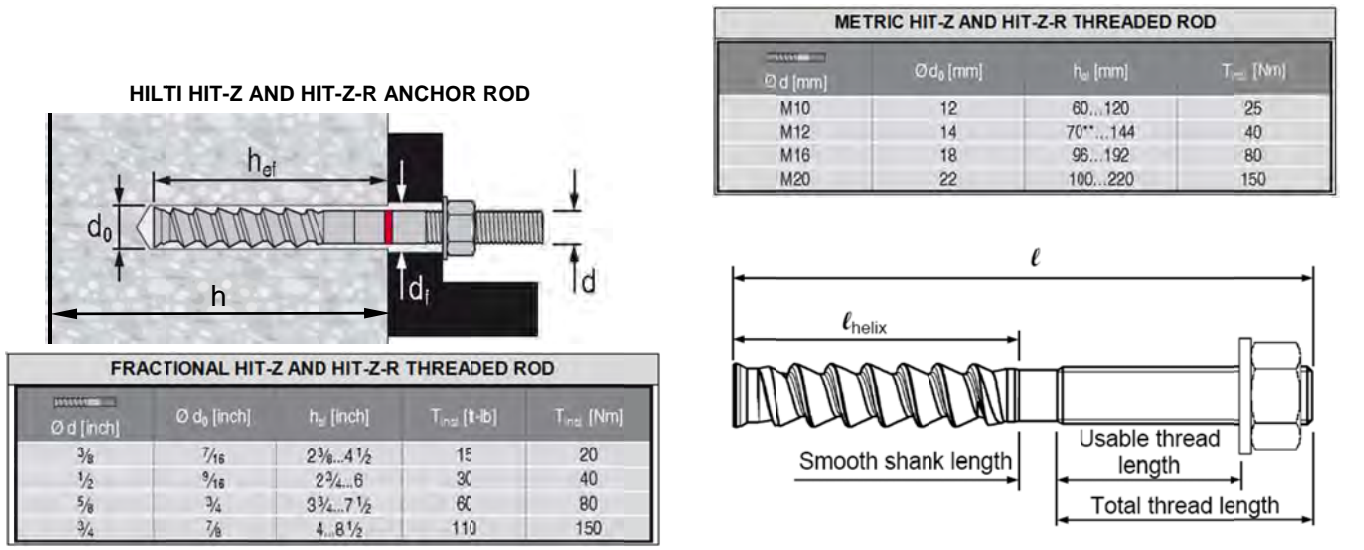

Name and Size	l Anchor Length		l <sub>helix</sub> Helix Length		Smooth Shank Length		Total Thread Length		Usable Thread Length	
	in	(mm)	in	(mm)	in	(mm)	in	(mm)	in	(mm)
HIT-Z(-R) 3/8" x 4 3/8"	4 3/8	(111)	2 1/4	(57)	5/16	(8)	1 13/16	(46)	1 5/16	(33)
HIT-Z(-R) 3/8" x 5 1/8"	5 1/8	(130)	2 1/4	(57)	5/16	(8)	2 9/16	(65)	2 1/16	(52)
HIT-Z(-R) 3/8" x 6 3/8"	6 3/8	(162)	2 1/4	(57)	5/16	(8)	3 13/16	(97)	3 5/16	(84)
HIT-Z(-R) 1/2" x 4 1/2"	4 1/2	(114)	2 1/2	(63)	5/16	(8)	1 11/16	(43)	1	(26)
HIT-Z(-R) 1/2" x 6 1/2"	6 1/2	(165)	2 1/2	(63)	5/16	(8)	3 11/16	(94)	3 1/16	(77)
HIT-Z(-R) 1/2" x 7 3/4"	7 3/4	(197)	2 1/2	(63)	5/16	(8)	4 15/16	(126)	4 5/16	(109)
HIT-Z(-R) 5/8" x 6"	6	(152)	3 5/8	(92)	7/16	(11)	1 15/16	(49)	1 1/8	(28)
HIT-Z(-R) 5/8" x 8"	8	(203)	3 5/8	(92)	7/16	(11)	3 15/16	(100)	3 1/8	(79)
HIT-Z(-R) 5/8" x 9 1/2"	9 1/2	(241)	3 5/8	(92)	1 15/16	(49)	3 15/16	(100)	3 1/8	(79)
HIT-Z(-R) 3/4" x 8 1/2"	8 1/2	(216)	4	(102)	7/16	(12)	4	(102)	3 1/16	(77)
HIT-Z(-R) 3/4" x 9 3/4"	9 3/4	(248)	4	(102)	1 11/16	(44)	4	(102)	3 1/16	(77)
HIT-Z(-R) M10x95	3 3/4	(95)	2 3/8	(60)	5/16	(8)	1 1/8	(27)	9/16	(14)
HIT-Z(-R) M10x115	4 1/2	(115)	2 3/8	(60)	5/16	(8)	1 7/8	(47)	1 5/16	(34)
HIT-Z(-R) M10x135	5 5/16	(135)	2 3/8	(60)	5/16	(8)	2 5/8	(67)	2 1/8	(54)
HIT-Z(-R) M10x160	6 5/16	(160)	2 3/8	(60)	5/16	(8)	3 5/8	(92)	3 1/8	(79)
HIT-Z(-R) M12x105	4 1/8	(105)	2 3/8	(60)	5/16	(8)	1 1/2	(37)	13/16	(21)
HIT-Z(-R) M12x140	5 1/2	(140)	2 3/8	(60)	5/16	(8)	2 7/8	(72)	2 3/16	(56)
HIT-Z(-R) M12x155	6 1/8	(155)	2 3/8	(60)	5/16	(8)	3 3/8	(87)	2 13/16	(71)
HIT-Z(-R) M12x196	7 3/4	(196)	2 3/8	(60)	5/16	(8)	5	(128)	4 7/16	(112)
HIT-Z(-R) M16x155	6 1/8	(155)	3 11/16	(93)	7/16	(11)	2	(51)	1 3/16	(30)
HIT-Z(-R) M16x175	6 7/8	(175)	3 11/16	(93)	7/16	(11)	2 13/16	(71)	1 15/16	(50)
HIT-Z(-R) M16x205	8 1/16	(205)	3 11/16	(93)	7/16	(11)	4	(101)	3 1/8	(80)
HIT-Z(-R) M16x240	9 7/16	(240)	3 11/16	(93)	1 1/4	(32)	4 1/2	(115)	3 11/16	(94)
HIT-Z(-R) M20x215	8 1/2	(215)	3 15/16	(100)	1/2	(13)	4	(102)	3 1/16	(78)
HIT-Z(-R) M20x250	9 13/16	(250)	3 15/16	(100)	1 7/8	(48)	4	(102)	3 1/16	(78)

FIGURE 1—INSTALLATION PARAMETERS FOR POST-INSTALLED ADHESIVE ANCHORS



**DEFORMED REINFORCEMENT**

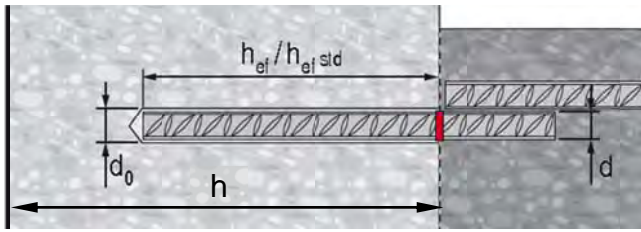

**US REBAR**

d	Ø d <sub>0</sub> [inch]	h <sub>ef</sub> [inch]	h <sub>ef</sub> [inch]
#3	1/2	3 3/8	2 3/8...7 1/2
#4	3/8	4 1/2	2 3/4...10
#5	3/4	5 5/8	3 1/2...12 1/2
#6	7/8	6 3/4	3 1/2...15
#7	1	7 7/8	3 1/2...17 1/2
#8	1 1/8	9	4...20
#9	1 3/8	10 1/8	4 1/2...22 1/2
#10	1 1/2	11 1/4	5...25

**CANADIAN REBAR**

d	Ø d <sub>0</sub> [inch]	h <sub>ef</sub> [mm]	h <sub>ef</sub> [mm]
10 M	3/16	115	70...226
15 M	3/4	145	80...320
20 M	1	200	90...390
25 M	1 1/4	230	101...504
30 M	1 1/2	280	120...598

**EUROPEAN REBAR**

Ø d [mm]	Ø d <sub>0</sub> [mm]	h <sub>ef</sub> [mm]	h <sub>ef</sub> [mm]
10	14	90	60...200
12	16	110	70...240
14	18	125	75...280
16	20	125	80...320
20	25	170	90...400
25	32	210	100...500
28	35	270	112...560
32	40	300	128...640

**THREADED ROD**

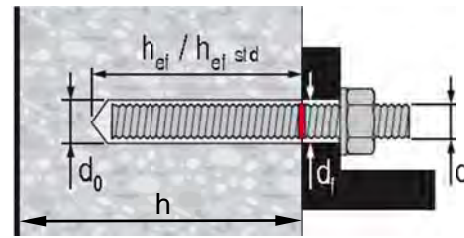

**FRACTIONAL THREADED ROD**

Ø d [inch]	Ø d <sub>0</sub> [inch]	h <sub>ef</sub> [inch]	h <sub>ef</sub> [inch]	T <sub>max</sub> [ft-lb]	T <sub>max</sub> [Nm]
3/8	7/16	3 3/8	2 3/8...7 1/2	15	20
1/2	9/16	4 1/2	2 3/4...10	30	41
5/8	3/4	5 5/8	3 1/2...12 1/2	60	81
3/4	7/8	6 3/4	3 1/2...15	100	136
7/8	1	7 7/8	3 1/2...17 1/2	125	169
1	1 1/8	9	4...20	150	203
1 1/4	1 3/8	11 1/4	5...25	200	271

**METRIC THREADED ROD**

Ø d [mm]	Ø d <sub>0</sub> [mm]	h <sub>ef</sub> [mm]	h <sub>ef</sub> [mm]	T <sub>max</sub> [Nm]
M10	12	90	60...200	20
M12	14	110	70...240	40
M16	18	125	80...320	80
M20	22	170	90...400	150
M24	28	210	96...480	200
M27	30	240	108...540	270
M30	35	270	120...600	300

**HILTI HIS-N AND HIS-RN THREADED INSERTS**

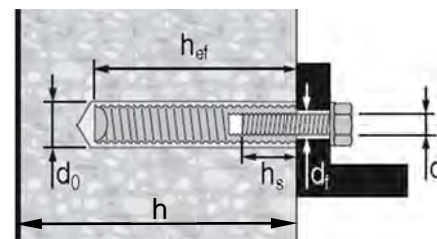

**FRACTIONAL HILTI HIS-N AND HIS-RN THREADED INSERTS**

Ø d [inch]	Ø d <sub>0</sub> [inch]	h <sub>ef</sub> [inch]	Ø d <sub>f</sub> [inch]	h <sub>s</sub> [inch]	T <sub>max</sub> [ft-lb]	T <sub>max</sub> [Nm]
3/8	1 1/16	4 3/8	7/16	3/8...1 1/16	15	20
1/2	7/8	5	9/16	1/2...1 3/16	30	41
5/8	1 1/8	6 3/4	1 1/16	5/8...1 1/2	60	81
3/4	1 1/4	8 1/8	1 3/16	3/4...1 7/8	100	136

**METRIC HILTI HIS-N AND HIS-RN THREADED INSERTS**

Ø d [mm]	Ø d <sub>0</sub> [mm]	h <sub>ef</sub> [mm]	Ø d <sub>f</sub> [mm]	h <sub>s</sub> [mm]	T <sub>max</sub> [Nm]
M8	14	90	9	8...20	10
M10	18	110	12	10...25	20
M12	22	125	14	12...30	40
M16	28	170	18	16...40	80
M20	32	235	22	20...50	150

FIGURE 1—INSTALLATION PARAMETERS FOR POST INSTALLED ADHESIVE ANCHORS (Continued)

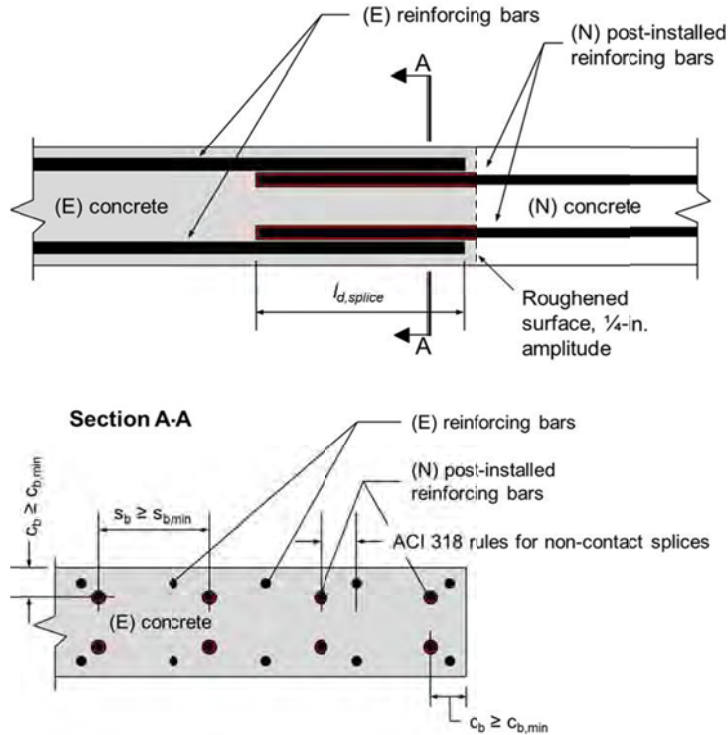

FIGURE 2—INSTALLATION PARAMETERS FOR POST-INSTALLED REINFORCING BARS

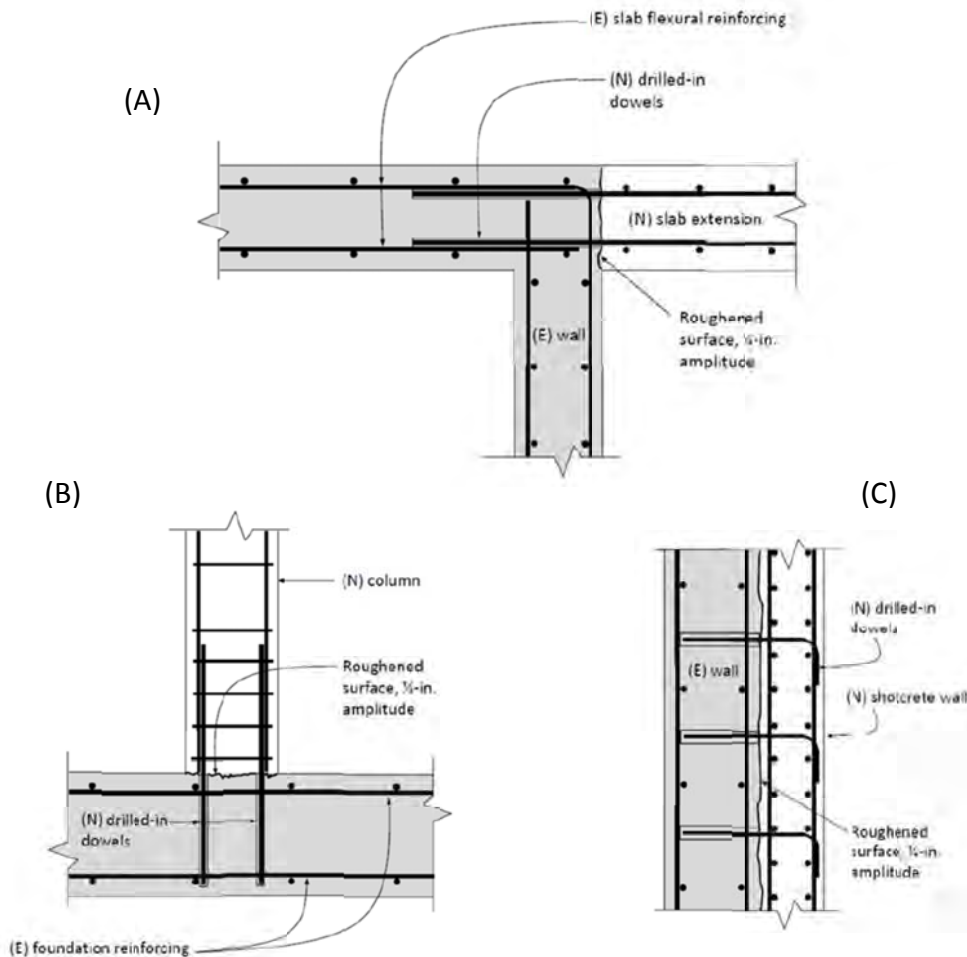





FIGURE 3—APPLICATION EXAMPLES FOR POST-INSTALLED REINFORCING BARS:

(A) TENSION LAP SPLICE WITH EXISTING FLEXURAL REINFORCEMENT; (B) TENSION DEVELOPMENT OF COLUMN DOWELS;

(C) DEVELOPMENT OF SHEAR DOWELS FOR NEWLY THICKENED SHEAR WALL

TABLE 1—DESIGN TABLE INDEX

Design Table		Fractional		Metric	
		Table	Page	Table	Page
 Hilti HIT-Z and HIT-Z-R Anchor Rod	Steel Strength - $N_{sa}, V_{sa}$	7	14	7	14
	Concrete Breakout - $N_{cb}, N_{cbg}, V_{cb}, V_{cbg}, V_{cp}, V_{cpq}$	8	15	8	15
	Pullout Strength - $N_p$	10	19	10	19
 Standard Threaded Rod	Steel Strength - $N_{sa}, V_{sa}$	11	20	15	24
	Concrete Breakout - $N_{cb}, N_{cbg}, V_{cb}, V_{cbg}, V_{cp}, V_{cpq}$	12	21	16	25
	Bond Strength - $N_a, N_{ag}$	14	23	18	27
 Hilti HIS-N and HIS-RN Internally Threaded Insert	Steel Strength - $N_{sa}, V_{sa}$	22	31	22	31
	Concrete Breakout - $N_{cb}, N_{cbg}, V_{cb}, V_{cbg}, V_{cp}, V_{cpq}$	23	32	23	32
	Bond Strength - $N_a, N_{ag}$	24	33	24	33

Design Table		Fractional		EU Metric		Canadian	
		Table	Page	Table	Page	Table	Page
 Steel Reinforcing Bars	Steel Strength - $N_{sa}, V_{sa}$	11	20	15	24	19	28
	Concrete Breakout - $N_{cb}, N_{cbg}, V_{cb}, V_{cbg}, V_{cp}, V_{cpq}$	12	21	16	25	20	29
	Bond Strength - $N_a, N_{ag}$	13	22	17	26	21	30
	Determination of development length for post-installed reinforcing bar connections	25	34	26	35	27	35

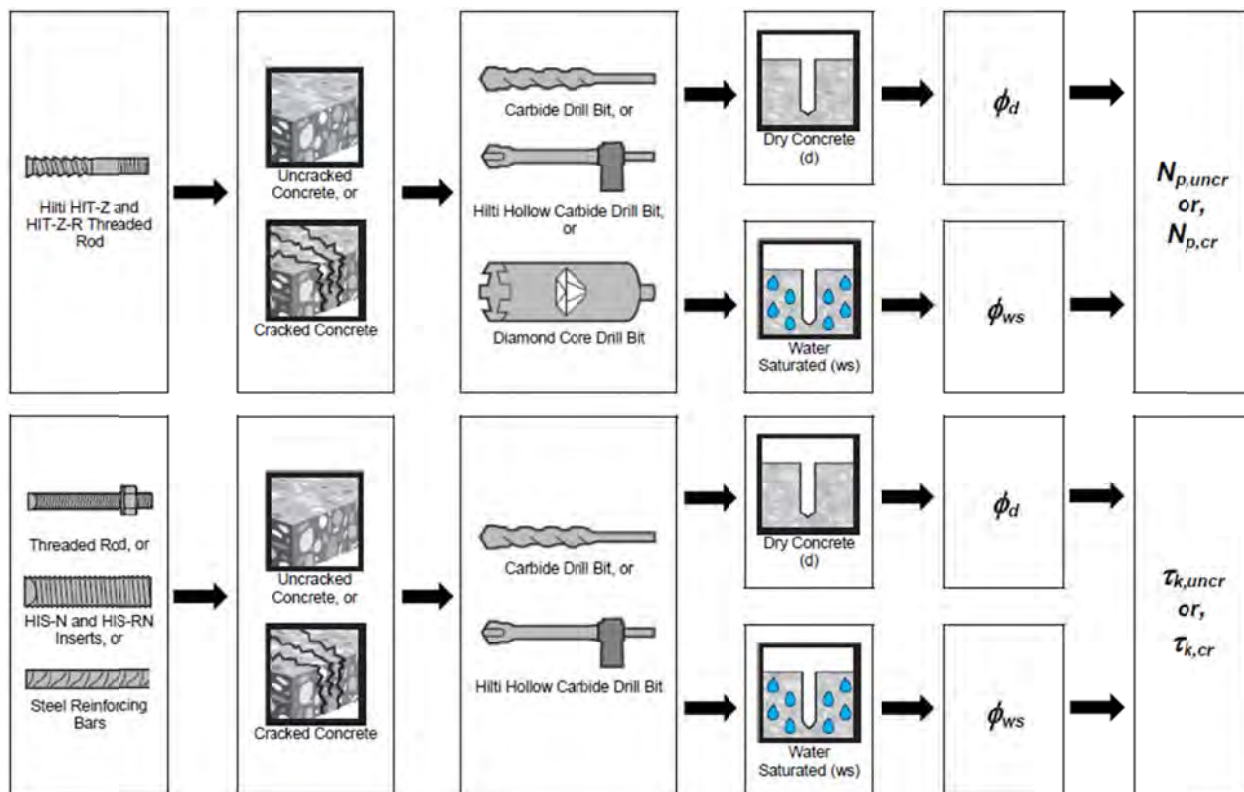



FIGURE 4—FLOWCHART FOR THE ESTABLISHMENT OF DESIGN BOND OR PULLOUT STRENGTH FOR POST-INSTALLED ADHESIVE ANCHORS

TABLE 2—SPECIFICATIONS AND PHYSICAL PROPERTIES OF FRACTIONAL AND METRIC HIT-Z AND HIT-Z RODS

HIT-Z AND HIT-Z-R ROD SPECIFICATION			Minimum specified ultimate strength, $f_{uta}$	Minimum specified yield strength 0.2 percent offset, $f_{ya}$	$f_{uta}/f_{ya}$	Elongation, min. percent	Reduction of Area, min. percent	Specification for nuts <sup>2</sup>
CARBON STEEL	 3/8-in. to 5/8-in. and M10 to M12 - AISI 1038 3/4-in. - AISI 1038 or 18MnV5	psi	94,200	75,300	1.25	8	20	ASTM A563 Grade A
		(MPa)	(650)	(520)				
	M16 - AISI 1038	psi	88,400	71,000				
		(MPa)	(610)	(490)				
	M20 - AISI 1038 or 18MnV5	psi	86,200	69,600				
		(MPa)	(595)	(480)				
STAINLESS STEEL	3/8-in. to 3/4-in. and M10 to M12 Grade 316 DIN-EN 10263-5 X5CrNiMo 17-12-2+AT	psi	94,200	75,300	1.25	8	20	ASTM F594 Type 316
		(MPa)	(650)	(520)				
	M16 Grade 316 DIN-EN 10263-5 X5CrNiMo 17-12-2+AT	psi	88,400	71,000				
		(MPa)	(610)	(490)				
	M20 Grade 316 DIN-EN 10263-5 X5CrNiMo 17-12-2+AT	psi	86,200	69,600				
		(MPa)	(595)	(480)				

<sup>1</sup> Steel properties are minimum values and maximum values will vary due to the cold forming of the rod.

<sup>2</sup> Nuts of other grades and styles having specified proof load stresses greater than the specified grade and style are also suitable. Nuts must have specified proof load stresses equal to or greater than the minimum tensile strength of the specified threaded rod.

TABLE 3—SPECIFICATIONS AND PHYSICAL PROPERTIES OF COMMON CARBON AND STAINLESS STEEL THREADED ROD MATERIALS<sup>1</sup>

THREADED ROD SPECIFICATION			Minimum specified ultimate strength, $f_{uta}$	Minimum specified yield strength 0.2 percent offset, $f_{ya}$	$f_{uta}/f_{ya}$	Elongation, min. percent <sup>7</sup>	Reduction of Area, min. percent	Specification for nuts <sup>8</sup>	
CARBON STEEL	 ASTM A193 <sup>2</sup> Grade B7 ≤ 2 1/2 in. (≤ 64 mm)	psi	125,000	105,000	1.19	16	50	ASTM A563 Grade DH	
		(MPa)	(862)	(724)					
		ASTM F568M <sup>3</sup> Class 5.8 M5 (1/4 in.) to M24 (1 in.) (equivalent to ISO 898-1)	psi	72,500	58,000	1.25	10	35	ASTM A563 Grade DH <sup>9</sup>
		(MPa)	(500)	(400)				DIN 934 (8-A2K)	
	ISO 898-1 <sup>4</sup> Class 5.8	MPa	500	400	1.25	22	-	DIN 934 Grade 6	
		(psi)	(72,500)	(58,000)					
	ISO 898-1 <sup>4</sup> Class 8.8	MPa	800	640	1.25	12	52	DIN 934 Grade 8	
		(psi)	(116,000)	(92,800)					
STAINLESS STEEL	ASTM F593 <sup>5</sup> CW1 (316) 1/4-in. to 5/8-in.	psi	100,000	65,000	1.54	20	-	ASTM F594	
		(MPa)	(689)	(448)					
	ASTM F593 <sup>5</sup> CW2 (316) 3/4-in. to 1 1/2-in.	psi	85,000	45,000	1.89	25	-	ASTM F594	
		(MPa)	(586)	(310)					
ISO 3506-1 <sup>6</sup> A4-70 M8 – M24	MPa	700	450	1.56	40	-	ISO 4032		
	(psi)	(101,500)	(65,250)						
ISO 3506-1 <sup>6</sup> A4-50 M27 – M30	MPa	500	210	2.38	40	-	ISO 4032		
	(psi)	(72,500)	(30,450)						

<sup>1</sup> Hilti HIT-HY 200 adhesive may be used in conjunction with all grades of continuously threaded carbon or stainless steel rod (all-thread) that comply with the code reference standards and that have thread characteristics comparable with ANSI B1.1 UNC Coarse Thread Series or ANSI B1.13M M Profile Metric Thread Series. Values for threaded rod types and associated nuts supplied by Hilti are provided here.

<sup>2</sup> Standard Specification for Alloy-Steel and Stainless Steel Bolting Materials for High-Temperature Service

<sup>3</sup> Standard Specification for Carbon and Alloy Steel Externally Threaded Metric Fasteners

<sup>4</sup> Mechanical properties of fasteners made of carbon steel and alloy steel – Part 1: Bolts, screws and studs

<sup>5</sup> Standard Steel Specification for Stainless Steel Bolts, Hex Cap Screws, and Studs

<sup>6</sup> Mechanical properties of corrosion-resistant stainless steel fasteners – Part 1: Bolts, screws and studs

<sup>7</sup> Based on 2-in. (50 mm) gauge length except for A 193, which are based on a gauge length of 4d and ISO 898, which is based on 5d.

<sup>8</sup> Nuts of other grades and styles having specified proof load stresses greater than the specified grade and style are also suitable. Nuts must have specified proof load stresses equal to or greater than the minimum tensile strength of the specified threaded rod.

<sup>9</sup> Nuts for fractional rods.

TABLE 4—SPECIFICATIONS AND PHYSICAL PROPERTIES OF COMMON STEEL REINFORCING BARS

REINFORCING BAR SPECIFICATION 		Minimum specified ultimate strength, $f_{uta}$	Minimum specified yield strength, $f_{ya}$
ASTM A615 <sup>1</sup> Gr. 60	psi (MPa)	90,000 (620)	60,000 (414)
ASTM A615 <sup>1</sup> Gr. 40	psi (MPa)	60,000 (414)	40,000 (276)
ASTM A706 <sup>2</sup> Gr. 60	psi (MPa)	80,000 (550)	60,000 (414)
DIN 488 <sup>3</sup> BSt 500	MPa (psi)	550 (79,750)	500 (72,500)
CAN/CSA-G30.18 <sup>4</sup> Gr. 400	MPa (psi)	540 (78,300)	400 (58,000)

<sup>1</sup> Standard Specification for Deformed and Plain Carbon Steel Bars for Concrete Reinforcement  
<sup>2</sup> Standard Specification for Low Alloy Steel Deformed and Plain Bars for Concrete Reinforcement  
<sup>3</sup> Reinforcing steel; reinforcing steel bars; dimensions and masses  
<sup>4</sup> Billet-Steel Bars for Concrete Reinforcement

TABLE 5—SPECIFICATIONS AND PHYSICAL PROPERTIES OF FRACTIONAL AND METRIC HIS-N AND HIS-RN INSERTS



HILTI HIS-N AND HIS-RN INSERTS 		Minimum specified ultimate strength, $f_{uta}$	Minimum specified yield strength, $f_{ya}$
Carbon Steel DIN EN 10277-3 11SMnPb30+c or DIN 1561 9SMnPb28K <sup>3</sup> / <sub>8</sub> -in. and M8 to M10	psi (MPa)	71,050 (490)	59,450 (410)
Carbon Steel DIN EN 10277-3 11SMnPb30+c or DIN 1561 9SMnPb28K <sup>1</sup> / <sub>2</sub> to <sup>3</sup> / <sub>4</sub> -in. and M12 to M20	psi (MPa)	66,700 (460)	54,375 (375)
Stainless Steel EN 10088-3 X5CrNiMo 17-12-2	psi (MPa)	101,500 (700)	50,750 (350)

TABLE 6—SPECIFICATIONS AND PHYSICAL PROPERTIES OF COMMON BOLTS, CAP SCREWS AND STUDS FOR USE WITH HIS-N AND HIS-RN INSERTS<sup>1,2</sup>

BOLT, CAP SCREW OR STUD SPECIFICATION 		Minimum specified ultimate strength $f_{uta}$	Minimum specified yield strength 0.2 percent offset $f_{ya}$	$f_{uta}/f_{ya}$	Elongation, min.	Reduction of Area, min.	Specification for nuts <sup>6</sup>
SAE J429 <sup>3</sup> Grade 5	psi (MPa)	120,000 (828)	92,000 (634)	1.30	14	35	SAE J995
ASTM A325 <sup>4</sup> <sup>1</sup> / <sub>2</sub> to 1-in.	psi (MPa)	120,000 (828)	92,000 (634)	1.30	14	35	A563 C, C3, D, DH, DH3 Heavy Hex
ASTM A193 <sup>5</sup> Grade B8M (AISI 316) for use with HIS-RN	psi (MPa)	110,000 (759)	95,000 (655)	1.16	15	45	ASTM F594 <sup>7</sup> Alloy Group 1, 2 or 3
ASTM A193 <sup>5</sup> Grade B8T (AISI 321) for use with HIS-RN	psi (MPa)	125,000 (862)	100,000 (690)	1.25	12	35	ASTM F594 <sup>7</sup> Alloy Group 1, 2 or 3

<sup>1</sup> Minimum Grade 5 bolts, cap screws or studs must be used with carbon steel HIS inserts.  
<sup>2</sup> Only stainless steel bolts, cap screws or studs must be used with HIS-RN inserts.  
<sup>3</sup> Mechanical and Material Requirements for Externally Threaded Fasteners  
<sup>4</sup> Standard Specification for Structural Bolts, Steel, Heat Treated, 120/105 ksi Minimum Tensile Strength  
<sup>5</sup> Standard Specification for Alloy-Steel and Stainless Steel Bolting Materials for High-Temperature Service  
<sup>6</sup> Nuts must have specified minimum proof load stress equal to or greater than the specified minimum full-size tensile strength of the specified stud.  
<sup>7</sup> Nuts for stainless steel studs must be of the same alloy group as the specified bolt, cap screw, or stud.



**TABLE 7—STEEL DESIGN INFORMATION FOR FRACTIONAL AND METRIC HIT-Z AND HIT-Z-R ANCHOR RODS**

DESIGN INFORMATION	Symbol	Units	Nominal Rod Dia. (in.) Fractional				Units	Nominal Rod Dia. (mm) Metric				
			<sup>3</sup> / <sub>8</sub>	<sup>1</sup> / <sub>2</sub>	<sup>5</sup> / <sub>8</sub>	<sup>3</sup> / <sub>4</sub>		10	12	16	20	
Rod O.D.	<i>d</i>	in. (mm)	0.375 (9.5)	0.5 (12.7)	0.625 (15.9)	0.75 (19.1)	mm (in.)	10 (0.39)	12 (0.47)	16 (0.63)	20 (0.79)	
Rod effective cross-sectional area	<i>A<sub>se</sub></i>	in. <sup>2</sup> (mm <sup>2</sup> )	0.0775 (50)	0.1419 (92)	0.2260 (146)	0.3340 (216)	mm <sup>2</sup> (in. <sup>2</sup> )	58.0 (0.090)	84.3 (0.131)	157.0 (0.243)	245.0 (0.380)	
CARBON STEEL	Nominal strength as governed by steel strength <sup>1</sup>	<i>N<sub>sa</sub></i>	lb (kN)	7,306 (32.5)	13,377 (59.5)	21,306 (94.8)	31,472 (140.0)	kN (lb)	37.7 (8,475)	54.8 (12,318)	95.8 (21,529)	145.8 (32,770)
		<i>V<sub>sa</sub></i>	lb (kN)	3,215 (14.3)	5,886 (26.2)	9,375 (41.7)	13,848 (61.6)	kN (lb)	16.6 (3,729)	24.1 (5,420)	42.2 (9,476)	64.2 (14,421)
	Reduction for seismic shear	<i>α<sub>v,seis</sub></i>	-	1.0	0.65		-	1.0	0.65			
	Strength reduction factor for tension <sup>2</sup>	<i>φ</i>	-	0.65		-	0.65					
	Strength reduction factor for shear <sup>2</sup>	<i>φ</i>	-	0.60		-	0.60					
STAINLESS STEEL	Nominal strength as governed by steel strength <sup>1</sup>	<i>N<sub>sa</sub></i>	lb (kN)	7,306 (32.5)	13,377 (59.5)	21,306 (94.8)	31,472 (140.0)	kN (lb)	37.7 (8,475)	54.8 (12,318)	95.8 (21,529)	145.8 (32,770)
		<i>V<sub>sa</sub></i>	lb (kN)	4,384 (19.5)	8,026 (35.7)	12,783 (56.9)	18,883 (84.0)	kN (lb)	22.6 (5,085)	32.9 (7,391)	57.5 (12,922)	87.5 (19,666)
	Reduction for seismic shear	<i>α<sub>v,seis</sub></i>	-	1.0	0.75	0.65		-	1.0	0.75	0.65	
	Strength reduction factor for tension <sup>2</sup>	<i>φ</i>	-	0.65		-	0.65					
	Strength reduction factor for shear <sup>2</sup>	<i>φ</i>	-	0.60		-	0.60					

For SI: 1 inch ≅ 25.4 mm, 1 lbf = 4.448 N, 1 psi = 0.006897 MPa.  
 For pound-inch units: 1 mm = 0.03937 inches, 1 N = 0.2248 lbf, 1 MPa = 145.0 psi

<sup>1</sup> Steel properties are minimum values and maximum values will vary due to the cold forming of the rod.

<sup>2</sup> For use with the load combinations of ACI 318-11 Section 9.2, as set forth in ACI 318-11 D.4.3.

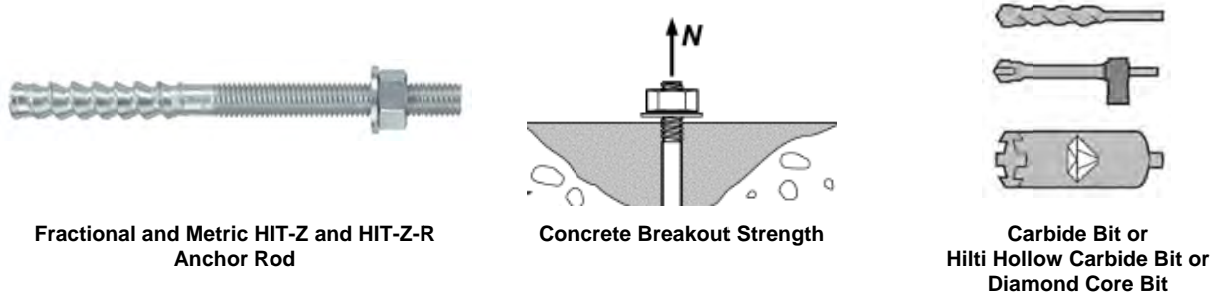
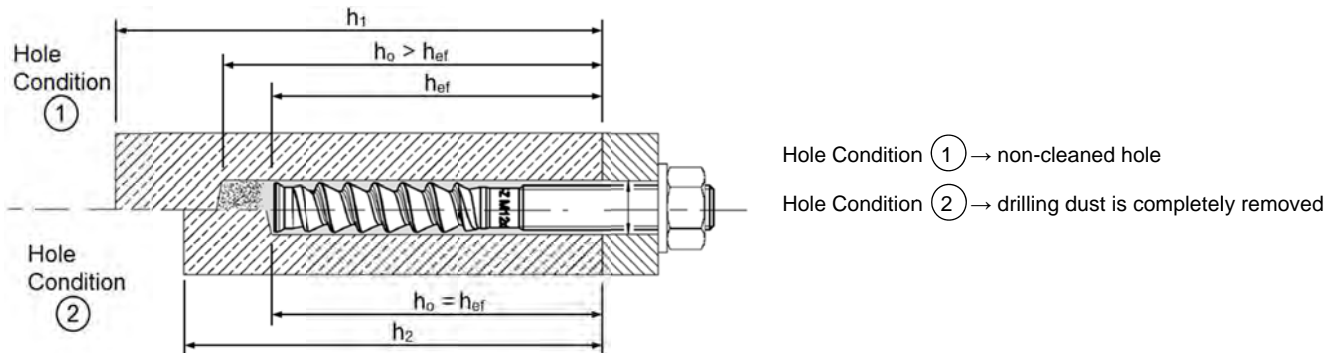

**TABLE 8—CONCRETE BREAKOUT DESIGN INFORMATION FOR U.S. CUSTOMARY UNIT HIT-Z AND HIT-Z-R ANCHOR ROD IN HOLES DRILLED WITH A HAMMER DRILL AND CARBIDE BIT (OR HILTI HOLLOW CARBIDE DRILL BIT) OR A CORE DRILL<sup>1</sup>**

DESIGN INFORMATION	Symbol	Units	Nominal Rod Dia. (in.) Fractional				Units	Nominal Rod Dia. (mm) Metric			
			<sup>3</sup> / <sub>8</sub>	<sup>1</sup> / <sub>2</sub>	<sup>5</sup> / <sub>8</sub>	<sup>3</sup> / <sub>4</sub>		10	12	16	20
Effectiveness factor for cracked concrete	$k_{c,cr}$	in-lb (SI)	17 (7.1)				SI (in-lb)	7.1 (17)			
Effectiveness factor for uncracked concrete	$k_{c,uncr}$	in-lb (SI)	24 (10)				SI (in-lb)	10 (24)			
Minimum embedment depth <sup>3</sup>	$h_{ef,min}$	in. (mm)	<sup>2</sup> / <sub>8</sub> (60)	<sup>2</sup> / <sub>4</sub> (70)	<sup>3</sup> / <sub>4</sub> (95)	4 (102)	mm (in.)	60 (2.4)	70 (2.8)	96 (3.8)	100 (3.9)
Maximum embedment depth <sup>3</sup>	$h_{ef,max}$	in. (mm)	<sup>4</sup> / <sub>2</sub> (114)	6 (152)	<sup>7</sup> / <sub>2</sub> (190)	<sup>8</sup> / <sub>2</sub> (216)	mm (in.)	120 (4.7)	144 (5.7)	192 (7.6)	220 (8.7)
Min. anchor spacing	$s_{min}$	-	See Section 4.1.9.1 of this report. Pre-calculated combinations of anchor spacing and edge distance are given in Table 9 of this report.				-	See Section 4.1.9.1 of this report. Pre-calculated combinations of anchor spacing and edge distance are given in Table 9 of this report.			
Min. edge distance	$c_{min}$	-	See Section 4.1.9.1 of this report. Pre-calculated combinations of anchor spacing and edge distance are given in Table 9 of this report.				-	See Section 4.1.9.1 of this report. Pre-calculated combinations of anchor spacing and edge distance are given in Table 9 of this report.			
Minimum concrete thickness Hole condition 1 <sup>3</sup>	$h_{min,1}$	in. (mm)	$h_{ef} + 2^{1}/4$ ( $h_{ef} + 57$ )		$h_{ef} + 4$ ( $h_{ef} + 102$ )		mm (in.)	$h_{ef} + 60$ ( $h_{ef} + 2.4$ )		$h_{ef} + 100$ ( $h_{ef} + 3.9$ )	
Minimum concrete thickness Hole condition 2 <sup>3</sup>	$h_{min,2}$	in. (mm)	$h_{ef} + 1^{1}/4 \geq 4$ ( $h_{ef} + 32 \geq 100$ )		$h_{ef} + 1^{3}/4$ ( $h_{ef} + 45$ )		mm (in.)	$h_{ef} + 30 \geq 100$ ( $h_{ef} + 1.25 \geq 3.9$ )		$h_{ef} + 45$ ( $h_{ef} + 1.8$ )	
Critical edge distance – splitting (for uncracked concrete)	$c_{ac}$	-	See Section 4.1.10.1 of this report				-	See Section 4.1.10.1 of this report			
Strength reduction factor for tension, concrete failure modes, Condition B <sup>2</sup>	$\phi$	-	0.65				-	0.65			
Strength reduction factor for shear, concrete failure modes, Condition B <sup>2</sup>	$\phi$	-	0.70				-	0.70			

For SI: 1 inch  $\equiv$  25.4 mm, 1 lbf = 4.448 N, 1 psi = 0.006897 MPa.  
For pound-inch units: 1 mm = 0.03937 inches, 1 N = 0.2248 lbf, 1 MPa = 145.0 psi

<sup>1</sup> Additional setting information is described in Figure 9, Manufacturers Printed Installation Instructions (MPII).  
<sup>2</sup> Values provided for post-installed anchors under Condition B without supplementary reinforcement as defined in ACI 318-11 Section D.4.3.  
<sup>3</sup> Borehole condition is described in Figure 5 below.



**FIGURE 5—BOREHOLE SETTING CONDITIONS FOR HILTI HIT-Z AND HIT-Z-R ANCHOR RODS**

TABLE 9—PRE-CALCULATED EDGE DISTANCE AND SPACING COMBINATIONS FOR HILTI HIT-Z AND HIT-Z-R RODS

DESIGN INFORMATION			Symbol	Units	Nominal Rod Diameter (in.) – Fractional								
Rod O.D.			<i>d</i>	in. (mm)	<sup>3</sup> / <sub>8</sub> (9.5)								
Effective embedment			<i>h<sub>ef</sub></i>	in. (mm)	2 <sup>3</sup> / <sub>8</sub> (60)			3 <sup>3</sup> / <sub>8</sub> (86)		4 <sup>1</sup> / <sub>2</sub> (114)			
Drilled hole condition <sup>1</sup>			-	-	2	1 or 2		2	1 or 2		2	1 or 2	
Minimum concrete thickness			<i>h</i>	in. (mm)	4 (102)	4 <sup>5</sup> / <sub>8</sub> (117)	5 <sup>3</sup> / <sub>4</sub> (146)	4 <sup>5</sup> / <sub>8</sub> (117)	5 <sup>5</sup> / <sub>8</sub> (143)	6 <sup>3</sup> / <sub>8</sub> (162)	5 <sup>3</sup> / <sub>4</sub> (146)	6 <sup>3</sup> / <sub>4</sub> (171)	7 <sup>3</sup> / <sub>8</sub> (187)
UNCRACKED CONCRETE	Minimum edge and spacing Case 1 <sup>2</sup>	<i>c<sub>min,1</sub></i>	in. (mm)	3 <sup>1</sup> / <sub>8</sub> (79)	2 <sup>3</sup> / <sub>4</sub> (70)	2 <sup>1</sup> / <sub>4</sub> (57)	2 <sup>3</sup> / <sub>4</sub> (70)	2 <sup>1</sup> / <sub>4</sub> (57)	2 (51)	2 <sup>1</sup> / <sub>4</sub> (57)	1 <sup>1</sup> / <sub>8</sub> (48)	1 <sup>1</sup> / <sub>8</sub> (48)	
		<i>s<sub>min,1</sub></i>	in. (mm)	9 <sup>1</sup> / <sub>8</sub> (232)	7 <sup>3</sup> / <sub>4</sub> (197)	6 <sup>1</sup> / <sub>8</sub> (156)	7 <sup>3</sup> / <sub>4</sub> (197)	6 <sup>1</sup> / <sub>2</sub> (165)	5 <sup>5</sup> / <sub>8</sub> (143)	6 <sup>1</sup> / <sub>8</sub> (156)	5 <sup>3</sup> / <sub>8</sub> (137)	4 <sup>1</sup> / <sub>2</sub> (114)	
	Minimum edge and spacing Case 2 <sup>2</sup>	<i>c<sub>min,2</sub></i>	in. (mm)	5 <sup>5</sup> / <sub>8</sub> (143)	4 <sup>3</sup> / <sub>4</sub> (121)	3 <sup>3</sup> / <sub>4</sub> (95)	4 <sup>3</sup> / <sub>4</sub> (121)	3 <sup>1</sup> / <sub>8</sub> (98)	3 <sup>1</sup> / <sub>4</sub> (83)	3 <sup>3</sup> / <sub>4</sub> (95)	3 <sup>1</sup> / <sub>8</sub> (79)	2 <sup>3</sup> / <sub>4</sub> (70)	
		<i>s<sub>min,2</sub></i>	in. (mm)	1 <sup>1</sup> / <sub>8</sub> (48)	1 <sup>1</sup> / <sub>8</sub> (48)	1 <sup>1</sup> / <sub>8</sub> (48)	1 <sup>1</sup> / <sub>8</sub> (48)	1 <sup>1</sup> / <sub>8</sub> (48)	1 <sup>1</sup> / <sub>8</sub> (48)	1 <sup>1</sup> / <sub>8</sub> (48)	1 <sup>1</sup> / <sub>8</sub> (48)	1 <sup>1</sup> / <sub>8</sub> (48)	
CRACKED CONCRETE	Minimum edge and spacing Case 1 <sup>2</sup>	<i>c<sub>min,1</sub></i>	in. (mm)	2 <sup>1</sup> / <sub>8</sub> (54)	1 <sup>1</sup> / <sub>8</sub> (48)	1 <sup>1</sup> / <sub>8</sub> (48)	1 <sup>1</sup> / <sub>8</sub> (48)	1 <sup>1</sup> / <sub>8</sub> (48)	1 <sup>1</sup> / <sub>8</sub> (48)	1 <sup>1</sup> / <sub>8</sub> (48)	1 <sup>1</sup> / <sub>8</sub> (48)	1 <sup>1</sup> / <sub>8</sub> (48)	
		<i>s<sub>min,1</sub></i>	in. (mm)	6 <sup>3</sup> / <sub>8</sub> (162)	5 <sup>1</sup> / <sub>2</sub> (140)	4 <sup>1</sup> / <sub>4</sub> (108)	5 <sup>1</sup> / <sub>2</sub> (140)	3 <sup>1</sup> / <sub>2</sub> (89)	2 <sup>3</sup> / <sub>8</sub> (67)	3 <sup>1</sup> / <sub>4</sub> (83)	2 (51)	1 <sup>1</sup> / <sub>8</sub> (48)	
	Minimum edge and spacing Case 2 <sup>2</sup>	<i>c<sub>min,2</sub></i>	in. (mm)	3 <sup>5</sup> / <sub>8</sub> (92)	3 <sup>1</sup> / <sub>8</sub> (79)	2 <sup>3</sup> / <sub>8</sub> (60)	3 <sup>1</sup> / <sub>8</sub> (79)	2 <sup>1</sup> / <sub>2</sub> (64)	2 <sup>1</sup> / <sub>8</sub> (54)	2 <sup>3</sup> / <sub>8</sub> (60)	2 (51)	1 <sup>1</sup> / <sub>8</sub> (48)	
		<i>s<sub>min,2</sub></i>	in. (mm)	1 <sup>1</sup> / <sub>8</sub> (48)	1 <sup>1</sup> / <sub>8</sub> (48)	1 <sup>1</sup> / <sub>8</sub> (48)	1 <sup>1</sup> / <sub>8</sub> (48)	1 <sup>1</sup> / <sub>8</sub> (48)	1 <sup>1</sup> / <sub>8</sub> (48)	1 <sup>1</sup> / <sub>8</sub> (48)	1 <sup>1</sup> / <sub>8</sub> (48)	1 <sup>1</sup> / <sub>8</sub> (48)	

DESIGN INFORMATION			Symbol	Units	Nominal Rod Diameter (in.) – Fractional								
Rod O.D.			<i>d</i>	in. (mm)	<sup>1</sup> / <sub>2</sub> (12.7)								
Effective embedment			<i>h<sub>ef</sub></i>	in. (mm)	2- <sup>3</sup> / <sub>4</sub> (70)			4 <sup>1</sup> / <sub>2</sub> (114)		6 (152)			
Drilled hole condition <sup>1</sup>			-	-	2	1 or 2		2	1 or 2		2	1 or 2	
Minimum concrete thickness			<i>h</i>	in. (mm)	4 (102)	5 (127)	7 <sup>1</sup> / <sub>8</sub> (181)	5 <sup>1</sup> / <sub>4</sub> (146)	6 <sup>1</sup> / <sub>4</sub> (171)	8 <sup>1</sup> / <sub>4</sub> (210)	7 <sup>1</sup> / <sub>4</sub> (184)	8 <sup>1</sup> / <sub>4</sub> (210)	9 <sup>3</sup> / <sub>4</sub> (248)
UNCRACKED CONCRETE	Minimum edge and spacing Case 1 <sup>2</sup>	<i>c<sub>min,1</sub></i>	in. (mm)	5 <sup>5</sup> / <sub>8</sub> (130)	4 <sup>1</sup> / <sub>8</sub> (105)	2 <sup>7</sup> / <sub>8</sub> (73)	3 <sup>3</sup> / <sub>8</sub> (92)	3 (76)	2 <sup>1</sup> / <sub>2</sub> (64)	2 <sup>1</sup> / <sub>8</sub> (73)	2 <sup>1</sup> / <sub>2</sub> (64)	2 <sup>1</sup> / <sub>2</sub> (64)	
		<i>s<sub>min,1</sub></i>	in. (mm)	14 <sup>1</sup> / <sub>8</sub> (378)	11 <sup>1</sup> / <sub>8</sub> (302)	8 <sup>5</sup> / <sub>8</sub> (219)	10 <sup>1</sup> / <sub>4</sub> (260)	9 (229)	7 <sup>1</sup> / <sub>4</sub> (184)	8 <sup>1</sup> / <sub>8</sub> (206)	7 <sup>1</sup> / <sub>4</sub> (184)	5 (127)	
	Minimum edge and spacing Case 2 <sup>2</sup>	<i>c<sub>min,2</sub></i>	in. (mm)	9 <sup>1</sup> / <sub>4</sub> (235)	7 <sup>1</sup> / <sub>4</sub> (184)	4 <sup>1</sup> / <sub>8</sub> (124)	6 <sup>1</sup> / <sub>4</sub> (159)	5 <sup>1</sup> / <sub>4</sub> (133)	4 <sup>1</sup> / <sub>8</sub> (105)	4 <sup>1</sup> / <sub>4</sub> (121)	4 <sup>1</sup> / <sub>8</sub> (105)	3 <sup>3</sup> / <sub>8</sub> (86)	
		<i>s<sub>min,2</sub></i>	in. (mm)	2 <sup>1</sup> / <sub>2</sub> (64)	2 <sup>1</sup> / <sub>2</sub> (64)	2 <sup>1</sup> / <sub>2</sub> (64)	2 <sup>1</sup> / <sub>2</sub> (64)	2 <sup>1</sup> / <sub>2</sub> (64)	2 <sup>1</sup> / <sub>2</sub> (64)	2 <sup>1</sup> / <sub>2</sub> (64)	2 <sup>1</sup> / <sub>2</sub> (64)	2 <sup>1</sup> / <sub>2</sub> (64)	
CRACKED CONCRETE	Minimum edge and spacing Case 1 <sup>2</sup>	<i>c<sub>min,1</sub></i>	in. (mm)	3 <sup>5</sup> / <sub>8</sub> (92)	3 (76)	2 <sup>1</sup> / <sub>2</sub> (64)	2 <sup>5</sup> / <sub>8</sub> (67)	2 <sup>1</sup> / <sub>2</sub> (64)	2 <sup>1</sup> / <sub>2</sub> (64)	2 <sup>1</sup> / <sub>2</sub> (64)	2 <sup>1</sup> / <sub>2</sub> (64)	2 <sup>1</sup> / <sub>2</sub> (64)	
		<i>s<sub>min,1</sub></i>	in. (mm)	10 <sup>1</sup> / <sub>8</sub> (276)	8 <sup>1</sup> / <sub>2</sub> (216)	6 (152)	7 <sup>3</sup> / <sub>8</sub> (187)	5 <sup>1</sup> / <sub>2</sub> (140)	3 <sup>3</sup> / <sub>8</sub> (79)	4 <sup>1</sup> / <sub>2</sub> (114)	3 <sup>3</sup> / <sub>8</sub> (79)	2 <sup>1</sup> / <sub>2</sub> (64)	
	Minimum edge and spacing Case 2 <sup>2</sup>	<i>c<sub>min,2</sub></i>	in. (mm)	6 <sup>1</sup> / <sub>2</sub> (165)	5 (127)	3 <sup>1</sup> / <sub>4</sub> (83)	4 <sup>1</sup> / <sub>4</sub> (108)	3 <sup>1</sup> / <sub>2</sub> (89)	2 <sup>1</sup> / <sub>4</sub> (70)	3 <sup>1</sup> / <sub>4</sub> (83)	2 <sup>3</sup> / <sub>4</sub> (70)	2 <sup>1</sup> / <sub>2</sub> (64)	
		<i>s<sub>min,2</sub></i>	in. (mm)	2 <sup>1</sup> / <sub>2</sub> (64)	2 <sup>1</sup> / <sub>2</sub> (64)	2 <sup>1</sup> / <sub>2</sub> (64)	2 <sup>1</sup> / <sub>2</sub> (64)	2 <sup>1</sup> / <sub>2</sub> (64)	2 <sup>1</sup> / <sub>2</sub> (64)	2 <sup>1</sup> / <sub>2</sub> (64)	2 <sup>1</sup> / <sub>2</sub> (64)	2 <sup>1</sup> / <sub>2</sub> (64)	

DESIGN INFORMATION			Symbol	Units	Nominal Rod Diameter (in.) – Fractional								
Rod O.D.			<i>d</i>	in. (mm)	<sup>5</sup> / <sub>8</sub> (15.9)								
Effective embedment			<i>h<sub>ef</sub></i>	in. (mm)	3 <sup>3</sup> / <sub>4</sub> (95)			5 <sup>5</sup> / <sub>8</sub> (143)		7 <sup>1</sup> / <sub>2</sub> (191)			
Drilled hole condition <sup>1</sup>			-	-	2	1 or 2		2	1 or 2		2	1 or 2	
Minimum concrete thickness			<i>h</i>	in. (mm)	5 <sup>1</sup> / <sub>2</sub> (140)	7 <sup>3</sup> / <sub>4</sub> (197)	9 <sup>3</sup> / <sub>8</sub> (238)	7 <sup>3</sup> / <sub>8</sub> (187)	9 <sup>5</sup> / <sub>8</sub> (244)	10 <sup>1</sup> / <sub>2</sub> (267)	9 <sup>1</sup> / <sub>4</sub> (235)	11 <sup>1</sup> / <sub>2</sub> (292)	12 <sup>1</sup> / <sub>4</sub> (311)
UNCRACKED CONCRETE	Minimum edge and spacing Case 1 <sup>2</sup>	<i>c<sub>min,1</sub></i>	in. (mm)	6 <sup>1</sup> / <sub>4</sub> (159)	4 <sup>1</sup> / <sub>2</sub> (114)	3 <sup>3</sup> / <sub>4</sub> (95)	4 <sup>5</sup> / <sub>8</sub> (117)	3 <sup>5</sup> / <sub>8</sub> (92)	3 <sup>1</sup> / <sub>4</sub> (83)	3 <sup>3</sup> / <sub>4</sub> (95)	3 <sup>1</sup> / <sub>8</sub> (79)	3 <sup>1</sup> / <sub>8</sub> (79)	
		<i>s<sub>min,1</sub></i>	in. (mm)	18 <sup>3</sup> / <sub>8</sub> (467)	12 <sup>7</sup> / <sub>8</sub> (327)	10 <sup>5</sup> / <sub>8</sub> (270)	13 <sup>1</sup> / <sub>8</sub> (352)	10 <sup>3</sup> / <sub>8</sub> (264)	9 <sup>3</sup> / <sub>4</sub> (248)	10 <sup>1</sup> / <sub>8</sub> (276)	8 <sup>3</sup> / <sub>8</sub> (213)	7 <sup>3</sup> / <sub>8</sub> (187)	
	Minimum edge and spacing Case 2 <sup>2</sup>	<i>c<sub>min,2</sub></i>	in. (mm)	11 <sup>3</sup> / <sub>8</sub> (289)	7 <sup>3</sup> / <sub>4</sub> (197)	6 <sup>1</sup> / <sub>4</sub> (159)	8 <sup>1</sup> / <sub>4</sub> (210)	6 <sup>1</sup> / <sub>8</sub> (156)	5 <sup>1</sup> / <sub>2</sub> (140)	6 <sup>3</sup> / <sub>8</sub> (162)	6 <sup>1</sup> / <sub>8</sub> (124)	4 <sup>1</sup> / <sub>8</sub> (117)	
		<i>s<sub>min,2</sub></i>	in. (mm)	3 <sup>1</sup> / <sub>8</sub> (79)	3 <sup>1</sup> / <sub>8</sub> (79)	3 <sup>1</sup> / <sub>8</sub> (79)	3 <sup>1</sup> / <sub>8</sub> (79)	3 <sup>1</sup> / <sub>8</sub> (79)	3 <sup>1</sup> / <sub>8</sub> (79)	3 <sup>1</sup> / <sub>8</sub> (79)	3 <sup>1</sup> / <sub>8</sub> (79)	3 <sup>1</sup> / <sub>8</sub> (79)	
CRACKED CONCRETE	Minimum edge and spacing Case 1 <sup>2</sup>	<i>c<sub>min,1</sub></i>	in. (mm)	4 <sup>5</sup> / <sub>8</sub> (117)	3 <sup>3</sup> / <sub>8</sub> (86)	3 <sup>1</sup> / <sub>8</sub> (79)	3 <sup>1</sup> / <sub>2</sub> (89)	3 <sup>1</sup> / <sub>8</sub> (79)	3 <sup>1</sup> / <sub>8</sub> (79)	3 <sup>1</sup> / <sub>8</sub> (79)	3 <sup>1</sup> / <sub>8</sub> (79)	3 <sup>1</sup> / <sub>8</sub> (79)	
		<i>s<sub>min,1</sub></i>	in. (mm)	13 <sup>3</sup> / <sub>8</sub> (352)	9 <sup>1</sup> / <sub>2</sub> (241)	8 <sup>3</sup> / <sub>4</sub> (222)	10 <sup>1</sup> / <sub>8</sub> (257)	6 <sup>1</sup> / <sub>2</sub> (165)	5 <sup>5</sup> / <sub>8</sub> (137)	7 <sup>1</sup> / <sub>8</sub> (181)	3 <sup>1</sup> / <sub>8</sub> (98)	3 <sup>1</sup> / <sub>8</sub> (79)	
	Minimum edge and spacing Case 2 <sup>2</sup>	<i>c<sub>min,2</sub></i>	in. (mm)	8 <sup>1</sup> / <sub>4</sub> (210)	5 <sup>1</sup> / <sub>2</sub> (140)	4 <sup>3</sup> / <sub>8</sub> (111)	5 <sup>1</sup> / <sub>8</sub> (149)	4 <sup>1</sup> / <sub>4</sub> (108)	3 <sup>1</sup> / <sub>8</sub> (98)	4 <sup>1</sup> / <sub>2</sub> (114)	3 <sup>3</sup> / <sub>8</sub> (86)	3 <sup>1</sup> / <sub>8</sub> (79)	
		<i>s<sub>min,2</sub></i>	in. (mm)	3 <sup>1</sup> / <sub>8</sub> (79)	3 <sup>1</sup> / <sub>8</sub> (79)	3 <sup>1</sup> / <sub>8</sub> (79)	3 <sup>1</sup> / <sub>8</sub> (79)	3 <sup>1</sup> / <sub>8</sub> (79)	3 <sup>1</sup> / <sub>8</sub> (79)	3 <sup>1</sup> / <sub>8</sub> (79)	3 <sup>1</sup> / <sub>8</sub> (79)	3 <sup>1</sup> / <sub>8</sub> (79)	

For S1: 1 inch ≡ 25.4 mm

<sup>1</sup> See Figure 5 for description of drilled hole condition.

<sup>2</sup> Linear interpolation is permitted to establish an edge distance and spacing combination between case 1 and case 2.

Linear interpolation for a specific edge distance *c*, where *c<sub>min,1</sub>* < *c* < *c<sub>min,2</sub>*, will determine the permissible spacing, *s*, as follows:

$$s \geq s_{min,2} + \frac{(s_{min,1} - s_{min,2})}{(c_{min,1} - c_{min,2})} (c - c_{min,2})$$



TABLE 9—PRE-CALCULATED EDGE DISTANCE AND SPACING COMBINATIONS FOR HILTI HIT-Z AND HIT-Z-R RODS (Continued)

DESIGN INFORMATION			Symbol	Units	Nominal Rod Diameter (in.) – Fractional								
Rod O.D.			<i>d</i>	in. (mm)	3/4 (19.1)								
Effective embedment			<i>h<sub>ef</sub></i>	in. (mm)	4 (102)			6 1/4 (171)		8 1/2 (216)			
Drilled hole condition <sup>1</sup>			-	-	2	1 or 2		2	1 or 2		2	1 or 2	
Minimum concrete thickness			<i>h</i>	in. (mm)	5 3/4 (146)	8 (203)	11 1/2 (292)	8 1/2 (216)	10 3/4 (273)	13 1/8 (333)	10 1/4 (260)	12 1/2 (318)	14 1/2 (368)
UNCRACKED CONCRETE	Minimum edge and spacing Case 1 <sup>2</sup>	<i>c<sub>min,1</sub></i>	in. (mm)	9 3/4 (248)	7 (178)	5 (127)	6 5/8 (168)	5 1/4 (133)	4 1/4 (108)	5 1/2 (140)	4 1/2 (114)	4 (102)	
		<i>s<sub>min,1</sub></i>	in. (mm)	28 3/4 (730)	20 5/8 (524)	14 (356)	19 3/8 (492)	15 1/4 (387)	12 5/8 (321)	16 (406)	13 1/4 (337)	11 (279)	
	Minimum edge and spacing Case 2 <sup>2</sup>	<i>c<sub>min,2</sub></i>	in. (mm)	18 1/8 (460)	12 5/8 (321)	8 1/2 (216)	11 1/8 (302)	9 1/8 (232)	7 1/4 (184)	9 1/8 (244)	7 3/4 (197)	6 1/2 (165)	
		<i>s<sub>min,2</sub></i>	in. (mm)	3 3/4 (95)	3 3/4 (95)	3 3/4 (95)	3 3/4 (95)	3 3/4 (95)	3 3/4 (95)	3 3/4 (95)	3 3/4 (95)	3 3/4 (95)	3 3/4 (95)
CRACKED CONCRETE	Minimum edge and spacing Case 1 <sup>2</sup>	<i>c<sub>min,1</sub></i>	in. (mm)	7 1/4 (184)	5 1/4 (133)	4 1/8 (105)	5 (127)	4 (102)	3 3/4 (95)	4 1/8 (105)	3 3/4 (95)	3 3/4 (95)	
		<i>s<sub>min,1</sub></i>	in. (mm)	21 3/4 (552)	15 1/2 (394)	12 1/4 (311)	14 1/2 (368)	11 3/8 (289)	9 (229)	12 1/8 (308)	8 3/4 (222)	6 1/2 (165)	
	Minimum edge and spacing Case 2 <sup>2</sup>	<i>c<sub>min,2</sub></i>	in. (mm)	13 1/4 (337)	9 1/4 (235)	6 (152)	8 5/8 (219)	6 5/8 (168)	5 1/8 (130)	7 (178)	5 1/2 (140)	4 1/2 (114)	
		<i>s<sub>min,2</sub></i>	in. (mm)	3 3/4 (95)	3 3/4 (95)	3 3/4 (95)	3 3/4 (95)	3 3/4 (95)	3 3/4 (95)	3 3/4 (95)	3 3/4 (95)	3 3/4 (95)	3 3/4 (95)

DESIGN INFORMATION			Symbol	Units	Nominal Rod Diameter (mm) – Metric								
Rod O.D.			<i>d</i>	mm (in.)	10 (0.39)								
Effective embedment			<i>h<sub>ef</sub></i>	mm (in.)	60 (2.36)			90 (3.54)		120 (4.72)			
Drilled hole condition <sup>1</sup>			-	-	2	1 or 2		2	1 or 2		2	1 or 2	
Minimum concrete thickness			<i>h</i>	mm (in.)	100 (3.94)	120 (4.72)	156 (6.14)	120 (4.72)	150 (5.91)	176 (6.91)	150 (5.91)	180 (7.09)	197 (7.74)
UNCRACKED CONCRETE	Minimum edge and spacing Case 1 <sup>2</sup>	<i>c<sub>min,1</sub></i>	mm (in.)	99 (3.90)	83 (3.27)	64 (2.52)	83 (3.27)	66 (2.60)	57 (2.24)	66 (2.60)	55 (2.17)	51 (2.01)	
		<i>s<sub>min,1</sub></i>	mm (in.)	295 (11.61)	244 (9.61)	187 (7.36)	244 (9.61)	197 (7.76)	166 (6.54)	197 (7.76)	164 (6.46)	148 (5.83)	
	Minimum edge and spacing Case 2 <sup>2</sup>	<i>c<sub>min,2</sub></i>	mm (in.)	181 (7.13)	148 (5.83)	110 (4.33)	148 (5.83)	115 (4.53)	96 (3.78)	115 (4.53)	93 (3.66)	84 (3.31)	
		<i>s<sub>min,2</sub></i>	mm (in.)	50 (1.97)	50 (1.97)	50 (1.97)	50 (1.97)	50 (1.97)	50 (1.97)	50 (1.97)	50 (1.97)	50 (1.97)	50 (1.97)
CRACKED CONCRETE	Minimum edge and spacing Case 1 <sup>2</sup>	<i>c<sub>min,1</sub></i>	mm (in.)	71 (2.80)	59 (2.32)	52 (2.05)	59 (2.32)	50 (1.97)	50 (1.97)	50 (1.97)	50 (1.97)	50 (1.97)	
		<i>s<sub>min,1</sub></i>	mm (in.)	209 (8.23)	174 (6.85)	150 (5.91)	174 (6.85)	131 (5.16)	106 (4.17)	131 (5.16)	84 (3.31)	66 (2.60)	
	Minimum edge and spacing Case 2 <sup>2</sup>	<i>c<sub>min,2</sub></i>	mm (in.)	124 (4.88)	101 (3.98)	74 (2.91)	101 (3.98)	77 (3.03)	64 (2.52)	77 (3.03)	62 (2.44)	55 (2.17)	
		<i>s<sub>min,2</sub></i>	mm (in.)	50 (1.97)	50 (1.97)	50 (1.97)	50 (1.97)	50 (1.97)	50 (1.97)	50 (1.97)	50 (1.97)	50 (1.97)	50 (1.97)

DESIGN INFORMATION			Symbol	Units	Nominal Rod Diameter (mm) – Metric								
Rod O.D.			<i>d</i>	mm (in.)	12 (0.47)								
Effective embedment			<i>h<sub>ef</sub></i>	mm (in.)	70 (2.76)			108 (4.25)		144 (5.67)			
Drilled hole condition <sup>1</sup>			-	-	2	1 or 2		2	1 or 2		2	1 or 2	
Minimum concrete thickness			<i>h</i>	mm (in.)	100 (3.94)	130 (5.12)	184 (7.24)	138 (5.43)	168 (6.61)	209 (8.21)	174 (6.85)	204 (8.03)	234 (9.21)
UNCRACKED CONCRETE	Minimum edge and spacing Case 1 <sup>2</sup>	<i>c<sub>min,1</sub></i>	mm (in.)	139 (5.47)	107 (4.21)	76 (2.99)	101 (3.98)	83 (3.27)	67 (2.64)	80 (3.15)	68 (2.68)	60 (2.36)	
		<i>s<sub>min,1</sub></i>	mm (in.)	416 (16.38)	320 (12.60)	225 (8.86)	300 (11.81)	247 (9.72)	199 (7.83)	239 (9.41)	204 (8.03)	176 (6.93)	
	Minimum edge and spacing Case 2 <sup>2</sup>	<i>c<sub>min,2</sub></i>	mm (in.)	258 (10.16)	194 (7.64)	131 (5.16)	181 (7.13)	146 (5.75)	114 (4.49)	140 (5.51)	116 (4.57)	99 (3.90)	
		<i>s<sub>min,2</sub></i>	mm (in.)	60 (2.36)	60 (2.36)	60 (2.36)	60 (2.36)	60 (2.36)	60 (2.36)	60 (2.36)	60 (2.36)	60 (2.36)	60 (2.36)
CRACKED CONCRETE	Minimum edge and spacing Case 1 <sup>2</sup>	<i>c<sub>min,1</sub></i>	mm (in.)	101 (3.98)	78 (3.07)	62 (2.44)	74 (2.91)	61 (2.40)	60 (2.36)	60 (2.36)	60 (2.36)	60 (2.36)	
		<i>s<sub>min,1</sub></i>	mm (in.)	303 (11.93)	232 (9.13)	186 (7.32)	217 (8.54)	178 (7.01)	126 (4.96)	168 (6.61)	117 (4.61)	79 (3.11)	
	Minimum edge and spacing Case 2 <sup>2</sup>	<i>c<sub>min,2</sub></i>	mm (in.)	182 (7.17)	136 (5.35)	90 (3.54)	127 (5.00)	101 (3.98)	77 (3.03)	96 (3.78)	79 (3.11)	67 (2.64)	
		<i>s<sub>min,2</sub></i>	mm (in.)	60 (2.36)	60 (2.36)	60 (2.36)	60 (2.36)	60 (2.36)	60 (2.36)	60 (2.36)	60 (2.36)	60 (2.36)	60 (2.36)

For SI: 1 inch ≅ 25.4 mm

<sup>1</sup> See Figure 5 for description of drilled hole condition.

<sup>2</sup> Linear interpolation is permitted to establish an edge distance and spacing combination between case 1 and case 2.

Linear interpolation for a specific edge distance *c*, where *c<sub>min,1</sub>* < *c* < *c<sub>min,2</sub>*, will determine the permissible spacing, *s*, as follows:

$$s \geq s_{min,2} + \frac{(s_{min,1} - s_{min,2})}{(c_{min,1} - c_{min,2})} (c - c_{min,2})$$

TABLE 9—PRE-CALCULATED EDGE DISTANCE AND SPACING COMBINATIONS FOR HILTI HIT-Z AND HIT-Z-R RODS (Continued)

DESIGN INFORMATION			Symbol	Units	Nominal Rod Diameter (mm) – Metric								
Rod O.D.			<i>d</i>	mm (in.)	16 (0.63)								
Effective embedment			<i>h<sub>ef</sub></i>	mm (in.)	96 (3.78)			144 (5.67)		192 (7.56)			
Drilled hole condition <sup>1</sup>			-	-	2	1 or 2		2	1 or 2		2	1 or 2	
Minimum concrete thickness			<i>h</i>	mm (in.)	141 (5.55)	196 (7.72)	237 (9.33)	189 (7.44)	244 (9.61)	269 (10.57)	237 (9.33)	292 (11.50)	312 (12.28)
UNCRACKED CONCRETE	Minimum edge and spacing Case 1 <sup>2</sup>	<i>c<sub>min,1</sub></i>	mm (in.)	158 (6.22)	114 (4.49)	94 (3.70)	118 (4.65)	92 (3.62)	83 (3.27)	94 (3.70)	80 (3.15)	80 (3.15)	
		<i>s<sub>min,1</sub></i>	mm (in.)	473 (18.62)	339 (13.35)	281 (11.06)	352 (13.86)	271 (10.67)	248 (9.76)	281 (11.06)	217 (8.54)	188 (7.40)	
	Minimum edge and spacing Case 2 <sup>2</sup>	<i>c<sub>min,2</sub></i>	mm (in.)	289 (11.38)	201 (7.91)	161 (6.34)	209 (8.23)	156 (6.14)	139 (5.47)	161 (6.34)	126 (4.96)	116 (4.57)	
		<i>s<sub>min,2</sub></i>	mm (in.)	80 (3.15)	80 (3.15)	80 (3.15)	80 (3.15)	80 (3.15)	80 (3.15)	80 (3.15)	80 (3.15)	80 (3.15)	80 (3.15)
CRACKED CONCRETE	Minimum edge and spacing Case 1 <sup>2</sup>	<i>c<sub>min,1</sub></i>	mm (in.)	116 (4.57)	83 (3.27)	80 (3.15)	86 (3.39)	80 (3.15)	80 (3.15)	80 (3.15)	80 (3.15)	80 (3.15)	
		<i>s<sub>min,1</sub></i>	mm (in.)	343 (13.50)	248 (9.76)	211 (8.31)	258 (10.16)	160 (6.30)	129 (5.08)	171 (6.73)	94 (3.70)	81 (3.19)	
	Minimum edge and spacing Case 2 <sup>2</sup>	<i>c<sub>min,2</sub></i>	mm (in.)	204 (8.03)	139 (5.47)	111 (4.37)	146 (5.75)	107 (4.21)	95 (3.74)	111 (4.37)	85 (3.35)	80 (3.15)	
		<i>s<sub>min,2</sub></i>	mm (in.)	80 (3.15)	80 (3.15)	80 (3.15)	80 (3.15)	80 (3.15)	80 (3.15)	80 (3.15)	80 (3.15)	80 (3.15)	80 (3.15)

DESIGN INFORMATION			Symbol	Units	Nominal Rod Diameter (mm) – Metric								
Rod O.D.			<i>d</i>	mm (in.)	20 (0.79)								
Effective embedment			<i>h<sub>ef</sub></i>	mm (in.)	100 (3.94)			180 (7.09)		220 (8.66)			
Drilled hole condition <sup>1</sup>			-	-	2	1 or 2		2	1 or 2		2	1 or 2	
Minimum concrete thickness			<i>h</i>	mm (in.)	145 (5.71)	200 (7.87)	282 (11.08)	225 (8.86)	280 (11.02)	335 (13.17)	265 (10.43)	320 (12.60)	370 (14.57)
UNCRACKED CONCRETE	Minimum edge and spacing Case 1 <sup>2</sup>	<i>c<sub>min,1</sub></i>	mm (in.)	235 (9.25)	170 (6.69)	121 (4.76)	152 (5.98)	122 (4.80)	103 (4.06)	129 (5.08)	107 (4.21)	100 (3.94)	
		<i>s<sub>min,1</sub></i>	mm (in.)	702 (27.64)	511 (20.12)	362 (14.25)	451 (17.76)	363 (14.29)	301 (11.85)	383 (15.08)	317 (12.48)	252 (9.92)	
	Minimum edge and spacing Case 2 <sup>2</sup>	<i>c<sub>min,2</sub></i>	mm (in.)	436 (17.17)	307 (12.09)	209 (8.23)	269 (10.59)	210 (8.27)	170 (6.69)	224 (8.82)	180 (7.09)	151 (5.94)	
		<i>s<sub>min,2</sub></i>	mm (in.)	100 (3.94)	100 (3.94)	100 (3.94)	100 (3.94)	100 (3.94)	100 (3.94)	100 (3.94)	100 (3.94)	100 (3.94)	100 (3.94)
CRACKED CONCRETE	Minimum edge and spacing Case 1 <sup>2</sup>	<i>c<sub>min,1</sub></i>	mm (in.)	176 (6.93)	128 (5.04)	102 (4.02)	114 (4.49)	100 (3.94)	100 (3.94)	100 (3.94)	100 (3.94)	100 (3.94)	
		<i>s<sub>min,1</sub></i>	mm (in.)	526 (20.71)	380 (14.96)	298 (11.73)	337 (13.27)	246 (9.69)	163 (6.42)	277 (10.91)	178 (7.01)	113 (4.45)	
	Minimum edge and spacing Case 2 <sup>2</sup>	<i>c<sub>min,2</sub></i>	mm (in.)	318 (12.52)	222 (8.74)	148 (5.83)	193 (7.60)	149 (5.87)	119 (4.69)	159 (6.26)	126 (4.96)	105 (4.13)	
		<i>s<sub>min,2</sub></i>	mm (in.)	100 (3.94)	100 (3.94)	100 (3.94)	100 (3.94)	100 (3.94)	100 (3.94)	100 (3.94)	100 (3.94)	100 (3.94)	100 (3.94)

For SI: 1 inch ≅ 25.4 mm

<sup>1</sup> See Figure 5 for description of drilled hole condition.

<sup>2</sup> Linear interpolation is permitted to establish an edge distance and spacing combination between case 1 and case 2.

Linear interpolation for a specific edge distance *c*, where *c<sub>min,1</sub>* < *c* < *c<sub>min,2</sub>*, will determine the permissible spacing, *s*, as follows:

$$s \geq s_{min2} + \frac{(s_{min1} - s_{min2})}{(c_{min1} - c_{min2})} (c - c_{min2})$$

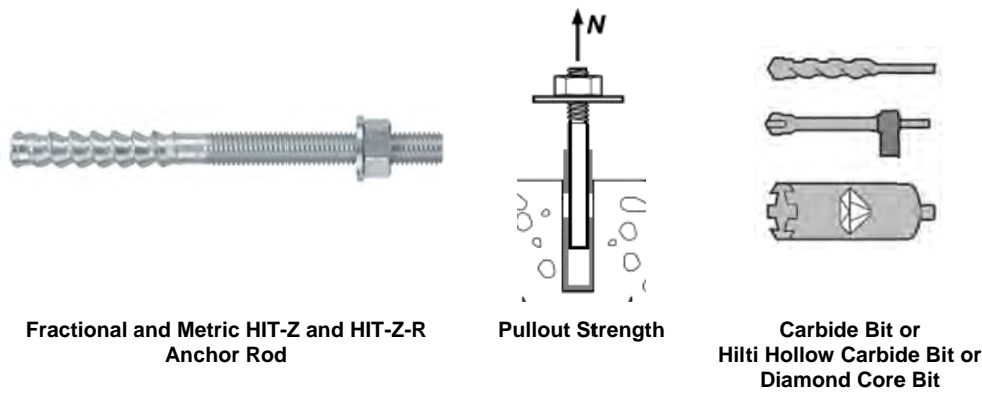

**TABLE 10—PULLOUT STRENGTH DESIGN INFORMATION FOR FRACTIONAL AND METRIC HILTI HIT-Z AND HIT-Z-R RODS IN HOLES DRILLED WITH A HAMMER DRILL AND CARBIDE BIT (OR HILTI HOLLOW CARBIDE DRILL BIT) OR A CORE DRILL<sup>1</sup>**

DESIGN INFORMATION		Symbol	Units	Nominal Rod Dia. (in.) Fractional				Units	Nominal Rod Dia. (mm) Metric			
				$\frac{3}{8}$	$\frac{1}{2}$	$\frac{5}{8}$	$\frac{3}{4}$		10	12	16	20
Minimum embedment depth		$h_{ef,min}$	in. (mm)	$2\frac{3}{8}$ (60)	$2\frac{3}{4}$ (70)	$3\frac{3}{4}$ (95)	4 (102)	mm (in.)	60 (2.4)	70 (2.8)	96 (3.8)	100 (3.9)
Maximum embedment depth		$h_{ef,max}$	in. (mm)	$4\frac{1}{2}$ (114)	6 (152)	$7\frac{1}{2}$ (190)	$8\frac{1}{2}$ (216)	mm (in.)	120 (4.7)	144 (5.7)	192 (7.6)	220 (8.7)
Temperature range A <sup>2</sup>	Pullout strength in cracked concrete	$N_{p,cr}$	lb (kN)	7,952 (35.4)	10,936 (48.6)	21,391 (95.1)	27,930 (124.2)	kN (lb)	39.1 (8,790)	43.8 (9,847)	98.0 (22,032)	127.9 (28,754)
	Pullout strength in uncracked concrete	$N_{p,uncr}$	lb (kN)	7,952 (35.4)	11,719 (52.1)	21,391 (95.1)	28,460 (126.6)	kN (lb)	39.1 (8,790)	46.9 (10,545)	98.0 (22,028)	130.3 (29,293)
Temperature range B <sup>2</sup>	Pullout strength in cracked concrete	$N_{p,cr}$	lb (kN)	7,952 (35.4)	10,936 (48.6)	21,391 (95.1)	27,930 (124.2)	kN (lb)	39.1 (8,790)	43.8 (9,847)	98.0 (22,032)	127.9 (28,754)
	Pullout strength in uncracked concrete	$N_{p,uncr}$	lb (kN)	7,952 (35.4)	11,719 (52.1)	21,391 (95.1)	28,460 (126.6)	kN (lb)	39.1 (8,790)	46.9 (10,545)	98.0 (22,028)	130.3 (29,293)
Temperature range C <sup>2</sup>	Pullout strength in cracked concrete	$N_{p,cr}$	lb (kN)	7,182 (31.9)	9,877 (43.9)	19,321 (85.9)	25,227 (112.2)	kN (lb)	35.3 (7,936)	39.5 (8,880)	88.5 (19,897)	115.5 (25,967)
	Pullout strength in uncracked concrete	$N_{p,uncr}$	lb (kN)	7,182 (31.9)	10,585 (47.1)	19,321 (85.9)	25,705 (114.3)	kN (lb)	35.3 (7,936)	42.4 (9,532)	88.5 (19,897)	117.7 (26,461)
Permissible installation conditions	Dry concrete, water saturated concrete	Anchor Category	-	1				-	1			
		$\phi_d, \phi_{ws}$	-	0.65				-	0.65			
Reduction for seismic tension		$\alpha_{N,seis}$	-	0.94	1.0			-	1.0	0.89	1.0	

For SI: 1 inch  $\equiv$  25.4 mm, 1 lbf = 4.448 N, 1 psi = 0.006897 MPa.  
 For pound-inch units: 1 mm = 0.03937 inches, 1 N = 0.2248 lbf, 1 MPa = 145.0 psi

<sup>1</sup> Temperature range A: Maximum short term temperature = 130°F (55°C), Maximum long term temperature = 110°F (43°C).  
 Temperature range B: Maximum short term temperature = 176°F (80°C), Maximum long term temperature = 110°F (43°C).  
 Temperature range C: Maximum short term temperature = 248°F (120°C), Maximum long term temperature = 162°F (72°C).  
 Short term elevated concrete temperatures are those that occur over brief intervals, e.g., as a result of diurnal cycling. Long term concrete temperatures are roughly constant over significant periods of time.



Fractional Threaded Rod and Reinforcing Bars Steel Strength

TABLE 11—STEEL DESIGN INFORMATION FOR FRACTIONAL THREADED ROD AND REINFORCING BARS

DESIGN INFORMATION		Symbol	Units	Nominal rod diameter (in.) <sup>1</sup>							
				<sup>3</sup> / <sub>8</sub>	<sup>1</sup> / <sub>2</sub>	<sup>5</sup> / <sub>8</sub>	<sup>3</sup> / <sub>4</sub>	<sup>7</sup> / <sub>8</sub>	1	1 <sup>1</sup> / <sub>4</sub>	
Rod O.D.		<i>d</i>	in. (mm)	0.375 (9.5)	0.5 (12.7)	0.625 (15.9)	0.75 (19.1)	0.875 (22.2)	1 (25.4)	1.25 (31.8)	
Rod effective cross-sectional area		<i>A<sub>se</sub></i>	in. <sup>2</sup> (mm <sup>2</sup> )	0.0775 (50)	0.1419 (92)	0.2260 (146)	0.3345 (216)	0.4617 (298)	0.6057 (391)	0.9691 (625)	
ISO 898-1 Class 5.8	Nominal strength as governed by steel strength	<i>N<sub>sa</sub></i>	lb (kN)	5,620 (25.0)	10,290 (45.8)	16,385 (72.9)	24,250 (107.9)	33,470 (148.9)	43,910 (195.3)	70,260 (312.5)	
		<i>V<sub>sa</sub></i>	lb (kN)	2,810 (12.5)	6,175 (27.5)	9,830 (43.7)	14,550 (64.7)	20,085 (89.3)	26,345 (117.2)	42,155 (187.5)	
	Reduction for seismic shear	$\alpha_{V,seis}$	-	0.70							
	Strength reduction factor for tension <sup>2</sup>	$\phi$	-	0.65							
	Strength reduction factor for shear <sup>2</sup>	$\phi$	-	0.60							
ASTM A193 B7	Nominal strength as governed by steel strength	<i>N<sub>sa</sub></i>	lb (kN)	9,685 (43.1)	17,735 (78.9)	28,250 (125.7)	41,810 (186.0)	57,710 (256.7)	75,710 (336.8)	121,135 (538.8)	
		<i>V<sub>sa</sub></i>	lb (kN)	4,845 (21.5)	10,640 (47.3)	16,950 (75.4)	25,085 (111.6)	34,625 (154.0)	45,425 (202.1)	72,680 (323.3)	
	Reduction for seismic shear	$\alpha_{V,seis}$	-	0.70							
	Strength reduction factor for tension <sup>3</sup>	$\phi$	-	0.75							
	Strength reduction factor for shear <sup>3</sup>	$\phi$	-	0.65							
ASTM F593, CW Stainless	Nominal strength as governed by steel strength	<i>N<sub>sa</sub></i>	lb (kN)	7,750 (34.5)	14,190 (63.1)	22,600 (100.5)	28,430 (126.5)	39,245 (174.6)	51,485 (229.0)	82,370 (366.4)	
		<i>V<sub>sa</sub></i>	lb (kN)	3,875 (17.2)	8,515 (37.9)	13,560 (60.3)	17,060 (75.9)	23,545 (104.7)	30,890 (137.4)	49,425 (219.8)	
	Reduction for seismic shear	$\alpha_{V,seis}$	-	0.70							
	Strength reduction factor for tension <sup>2</sup>	$\phi$	-	0.65							
	Strength reduction factor for shear <sup>2</sup>	$\phi$	-	0.60							
DESIGN INFORMATION		Symbol	Units	Nominal Reinforcing bar size (Rebar)							
				#3	#4	#5	#6	#7	#8	#9	#10
Nominal bar diameter		<i>d</i>	in. (mm)	<sup>3</sup> / <sub>8</sub> (9.5)	<sup>1</sup> / <sub>2</sub> (12.7)	<sup>5</sup> / <sub>8</sub> (15.9)	<sup>3</sup> / <sub>4</sub> (19.1)	<sup>7</sup> / <sub>8</sub> (22.2)	1 (25.4)	1 <sup>1</sup> / <sub>8</sub> (28.6)	1 <sup>1</sup> / <sub>4</sub> (31.8)
Bar effective cross-sectional area		<i>A<sub>se</sub></i>	in. <sup>2</sup> (mm <sup>2</sup> )	0.11 (71)	0.2 (129)	0.31 (200)	0.44 (284)	0.6 (387)	0.79 (510)	1.0 (645)	1.27 (819)
ASTM A615 Grade 40	Nominal strength as governed by steel strength	<i>N<sub>sa</sub></i>	lb (kN)	6,600 (29.4)	12,000 (53.4)	18,600 (82.7)	26,400 (117.4)	36,000 (160.1)	47,400 (210.9)	60,000 (266.9)	76,200 (339.0)
		<i>V<sub>sa</sub></i>	lb (kN)	3,960 (17.6)	7,200 (32.0)	11,160 (49.6)	15,840 (70.5)	21,600 (96.1)	28,440 (126.5)	36,000 (160.1)	45,720 (203.4)
	Reduction for seismic shear	$\alpha_{V,seis}$	-	0.70							
	Strength reduction factor $\phi$ for tension <sup>2</sup>	$\phi$	-	0.65							
	Strength reduction factor $\phi$ for shear <sup>2</sup>	$\phi$	-	0.60							
ASTM A615 Grade 60	Nominal strength as governed by steel strength	<i>N<sub>sa</sub></i>	lb (kN)	9,900 (44.0)	18,000 (80.1)	27,900 (124.1)	39,600 (176.2)	54,000 (240.2)	71,100 (316.3)	90,000 (400.4)	114,300 (508.5)
		<i>V<sub>sa</sub></i>	lb (kN)	5,940 (26.4)	10,800 (48.0)	16,740 (74.5)	23,760 (105.7)	32,400 (144.1)	42,660 (189.8)	54,000 (240.2)	68,580 (305.1)
	Reduction for seismic shear	$\alpha_{V,seis}$	-	0.70							
	Strength reduction factor $\phi$ for tension <sup>2</sup>	$\phi$	-	0.65							
	Strength reduction factor $\phi$ for shear <sup>2</sup>	$\phi$	-	0.60							
ASTM A706 Grade 60	Nominal strength as governed by steel strength	<i>N<sub>sa</sub></i>	lb (kN)	8,800 (39.1)	16,000 (71.2)	24,800 (110.3)	35,200 (156.6)	48,000 (213.5)	63,200 (281.1)	80,000 (355.9)	101,600 (452.0)
		<i>V<sub>sa</sub></i>	lb (kN)	5,280 (23.5)	9,600 (42.7)	14,880 (66.2)	21,120 (94.0)	28,800 (128.1)	37,920 (168.7)	48,000 (213.5)	60,960 (271.2)
	Reduction for seismic shear	$\alpha_{V,seis}$	-	0.70							
	Strength reduction factor $\phi$ for tension <sup>3</sup>	$\phi$	-	0.75							
	Strength reduction factor $\phi$ for shear <sup>3</sup>	$\phi$	-	0.65							

For **SI**: 1 inch = 25.4 mm, 1 lbf = 4.448 N. For **pound-inch** units: 1 mm = 0.03937 inches, 1 N = 0.2248 lbf

<sup>1</sup> Values provided for common rod material types are based on specified strengths and calculated in accordance with ACI 318-11 Eq. (D-2) and Eq. (D-29). Nuts and washers must be appropriate for the rod.

<sup>2</sup> For use with the load combinations of IBC Section 1605.2 or ACI 318-11 Section 9.2, as set forth in ACI 318-11 D.4.3. If the load combinations of ACI 318-11 Appendix C are used, the appropriate value of  $\phi$  must be determined in accordance with ACI 318-11 D.4.4. Values correspond to a brittle steel element.

<sup>3</sup> For use with the load combinations of IBC Section 1605.2 or ACI 318-11 Section 9.2, as set forth in ACI 318-11 D.4.3. If the load combinations of ACI 318-11 Appendix C are used, the appropriate value of  $\phi$  must be determined in accordance with ACI 318-11 D.4.4. Values correspond to a ductile steel element.

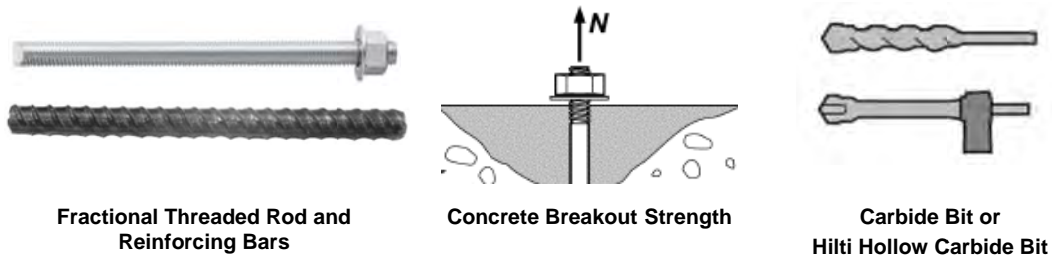
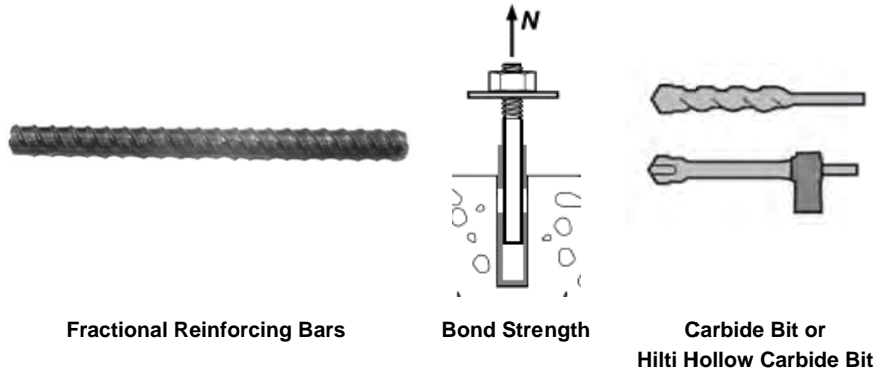

**TABLE 12—CONCRETE BREAKOUT DESIGN INFORMATION FOR FRACTIONAL THREADED ROD AND REINFORCING BARS IN HOLES DRILLED WITH A HAMMER DRILL AND CARBIDE BIT (OR HILTI HOLLOW CARBIDE DRILL BIT)<sup>1</sup>**

DESIGN INFORMATION	Symbol	Units	Nominal rod diameter (in.) / Reinforcing bar size							
			<sup>3</sup> / <sub>8</sub> or #3	<sup>1</sup> / <sub>2</sub> or #4	<sup>5</sup> / <sub>8</sub> or #5	<sup>3</sup> / <sub>4</sub> or #6	<sup>7</sup> / <sub>8</sub> or #7	1 or #8	#9	1 <sup>1</sup> / <sub>4</sub> or #10
Effectiveness factor for cracked concrete	$k_{c,cr}$	in-lb (SI)	17 (7.1)							
Effectiveness factor for uncracked concrete	$k_{c,uncr}$	in-lb (SI)	24 (10)							
Minimum Embedment	$h_{ef,min}$	in. (mm)	2 <sup>3</sup> / <sub>8</sub> (60)	2 <sup>3</sup> / <sub>4</sub> (70)	3 <sup>1</sup> / <sub>8</sub> (79)	3 <sup>1</sup> / <sub>2</sub> (89)	3 <sup>1</sup> / <sub>2</sub> (89)	4 (102)	4 <sup>1</sup> / <sub>2</sub> (114)	5 (127)
Maximum Embedment	$h_{ef,max}$	in. (mm)	7 <sup>1</sup> / <sub>2</sub> (191)	10 (254)	12 <sup>1</sup> / <sub>2</sub> (318)	15 (381)	17 <sup>1</sup> / <sub>2</sub> (445)	20 (508)	22 <sup>1</sup> / <sub>2</sub> (572)	25 (635)
Min. anchor spacing <sup>3</sup>	$s_{min}$	in. (mm)	1 <sup>7</sup> / <sub>8</sub> (48)	2 <sup>1</sup> / <sub>2</sub> (64)	3 <sup>1</sup> / <sub>8</sub> (79)	3 <sup>3</sup> / <sub>4</sub> (95)	4 <sup>3</sup> / <sub>8</sub> (111)	5 (127)	5 <sup>5</sup> / <sub>8</sub> (143)	6 <sup>1</sup> / <sub>4</sub> (159)
Min. edge distance <sup>3</sup>	$c_{min}$	-	5d; or see Section 4.1.9.2 of this report for design with reduced minimum edge distances							
Minimum concrete thickness	$h_{min}$	in. (mm)	$h_{ef} + 1\frac{1}{4}$ ( $h_{ef} + 30$ )			$h_{ef} + 2d_o^{(4)}$				
Critical edge distance – splitting (for uncracked concrete)	$c_{ac}$	-	See Section 4.1.10.2 of this report.							
Strength reduction factor for tension, concrete failure modes, Condition B <sup>2</sup>	$\phi$	-	0.65							
Strength reduction factor for shear, concrete failure modes, Condition B <sup>2</sup>	$\phi$	-	0.70							

For SI: 1 inch ≅ 25.4 mm, 1 lbf = 4.448 N, 1 psi = 0.006897 MPa.  
 For pound-inch units: 1 mm = 0.03937 inches, 1 N = 0.2248 lbf, 1 MPa = 145.0 psi

<sup>1</sup> Additional setting information is described in Figure 9, Manufacturers Printed Installation Instructions (MPII).  
<sup>2</sup> Values provided for post-installed anchors under Condition B without supplementary reinforcement as defined in ACI 318-11 Section D.4.3.  
<sup>3</sup> For installations with 1<sup>3</sup>/<sub>4</sub>-inch edge distance, refer to Section 4.1.9.2 for spacing and maximum torque requirements.  
<sup>4</sup>  $d_o$  = hole diameter.



**TABLE 13—BOND STRENGTH DESIGN INFORMATION FOR FRACTIONAL REINFORCING BARS IN HOLES DRILLED WITH A HAMMER DRILL AND CARBIDE BIT (OR HILTI HOLLOW CARBIDE DRILL BIT)<sup>1</sup>**

DESIGN INFORMATION		Symbol	Units	Nominal reinforcing bar size							
				#3	#4	#5	#6	#7	#8	#9	#10
Minimum Embedment		$h_{ef,min}$	in. (mm)	2 <sup>3</sup> / <sub>8</sub> (60)	2 <sup>3</sup> / <sub>4</sub> (70)	3 <sup>1</sup> / <sub>8</sub> (79)	3 <sup>1</sup> / <sub>2</sub> (89)	3 <sup>1</sup> / <sub>2</sub> (89)	4 (102)	4 <sup>1</sup> / <sub>2</sub> (114)	5 (127)
Maximum Embedment		$h_{ef,max}$	in. (mm)	7 <sup>1</sup> / <sub>2</sub> (191)	10 (254)	12 <sup>1</sup> / <sub>2</sub> (318)	15 (381)	17 <sup>1</sup> / <sub>2</sub> (445)	20 (508)	22 <sup>1</sup> / <sub>2</sub> (572)	25 (635)
Temperature range A <sup>2</sup>	Characteristic bond strength in cracked concrete	$\tau_{k,cr}$	psi (MPa)	1,080 (7.4)	1,080 (7.4)	1,090 (7.5)	1,090 (7.5)	835 (5.7)	840 (5.8)	850 (5.9)	850 (5.9)
	Characteristic bond strength in uncracked concrete	$\tau_{k,uncr}$	psi (MPa)	1,560 (10.8)	1,560 (10.8)	1,560 (10.8)	1,560 (10.8)	1,560 (10.8)	1,560 (10.8)	1,560 (10.8)	1,560 (10.8)
Temperature range B <sup>2</sup>	Characteristic bond strength in cracked concrete	$\tau_{k,cr}$	psi (MPa)	990 (6.8)	995 (6.9)	1000 (6.9)	1005 (6.9)	770 (5.3)	775 (5.3)	780 (5.4)	780 (5.4)
	Characteristic bond strength in uncracked concrete	$\tau_{k,uncr}$	psi (MPa)	1,435 (9.9)	1,435 (9.9)	1,435 (9.9)	1,435 (9.9)	1,435 (9.9)	1,435 (9.9)	1,435 (9.9)	1,435 (9.9)
Temperature range C <sup>2</sup>	Characteristic bond strength in cracked concrete	$\tau_{k,cr}$	psi (MPa)	845 (5.8)	850 (5.9)	855 (5.9)	855 (5.9)	660 (4.5)	665 (4.6)	665 (4.6)	670 (4.6)
	Characteristic bond strength in uncracked concrete	$\tau_{k,uncr}$	psi (MPa)	1,230 (8.5)	1,230 (8.5)	1,230 (8.5)	1,230 (8.5)	1,230 (8.5)	1,230 (8.5)	1,230 (8.5)	1,230 (8.5)
Permissible installation conditions	Dry concrete	Anchor Category	-	1							
		$\phi_d$	-	0.65							
	Water saturated concrete	Anchor Category	-	2							
		$\phi_{ws}$	-	0.55							
Reduction for seismic tension		$\alpha_{N,seis}$	-	0.8			0.85	0.90	0.95	1.0	

For SI: 1 inch ≡ 25.4 mm, 1 lbf = 4.448 N, 1 psi = 0.006897 MPa.  
 For pound-inch units: 1 mm = 0.03937 inches, 1 N = 0.2248 lbf, 1 MPa = 145.0 psi

<sup>1</sup>Bond strength values correspond to concrete compressive strength  $f'_c = 2,500$  psi (17.2 MPa). For concrete compressive strength,  $f'_c$ , between 2,500 psi (17.2 MPa) and 8,000 psi (55.2 MPa), the tabulated characteristic bond strength may be increased by a factor of  $(f'_c / 2,500)^{0.1}$  [For SI:  $(f'_c / 17.2)^{0.1}$ ]. See Section 4.1.4 of this report for bond strength determination.

<sup>2</sup>Temperature range A: Maximum short term temperature = 130°F (55°C), Maximum long term temperature = 110°F (43°C).

Temperature range B: Maximum short term temperature = 176°F (80°C), Maximum long term temperature = 110°F (43°C).

Temperature range C: Maximum short term temperature = 248°F (120°C), Maximum long term temperature = 162°F (72°C).

Short term elevated concrete temperatures are those that occur over brief intervals, e.g., as a result of diurnal cycling. Long term concrete temperatures are roughly constant over significant periods of time.

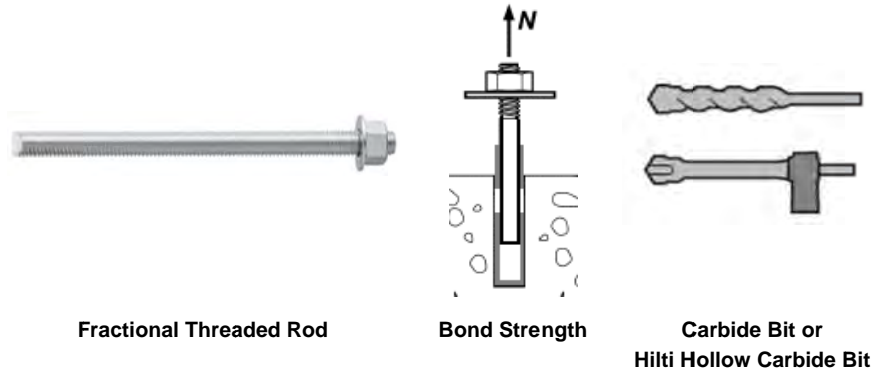

**TABLE 14—BOND STRENGTH DESIGN INFORMATION FOR FRACTIONAL THREADED ROD IN HOLES DRILLED WITH A HAMMER DRILL AND CARBIDE BIT (OR HILTI HOLLOW CARBIDE DRILL BIT)<sup>1</sup>**

DESIGN INFORMATION		Symbol	Units	Nominal rod diameter (in.)						
				<sup>3</sup> / <sub>8</sub>	<sup>1</sup> / <sub>2</sub>	<sup>5</sup> / <sub>8</sub>	<sup>3</sup> / <sub>4</sub>	<sup>7</sup> / <sub>8</sub>	1	1 <sup>1</sup> / <sub>4</sub>
Minimum Embedment		$h_{ef,min}$	in. (mm)	2 <sup>3</sup> / <sub>8</sub> (60)	2 <sup>3</sup> / <sub>4</sub> (70)	3 <sup>1</sup> / <sub>8</sub> (79)	3 <sup>1</sup> / <sub>2</sub> (89)	3 <sup>1</sup> / <sub>2</sub> (89)	4 (102)	5 (127)
Maximum Embedment		$h_{ef,max}$	in. (mm)	7 <sup>1</sup> / <sub>2</sub> (191)	10 (254)	12 <sup>1</sup> / <sub>2</sub> (318)	15 (381)	17 <sup>1</sup> / <sub>2</sub> (445)	20 (508)	25 (635)
Temperature range A <sup>2</sup>	Characteristic bond strength in cracked concrete	$\tau_{k,cr}$	psi (MPa)	930 (6.4)	935 (6.4)	940 (6.5)	945 (6.5)	800 (5.5)	805 (5.5)	810 (5.6)
	Characteristic bond strength in uncracked concrete	$\tau_{k,uncr}$	psi (MPa)	1,670 (11.5)	1,670 (11.5)	1,670 (11.5)	1,670 (11.5)	1,670 (11.5)	1,670 (11.5)	1,670 (11.5)
Temperature range B <sup>2</sup>	Characteristic bond strength in cracked concrete	$\tau_{k,cr}$	psi (MPa)	855 (5.9)	860 (5.9)	865 (6.0)	870 (6.0)	735 (5.1)	740 (5.1)	745 (5.1)
	Characteristic bond strength in uncracked concrete	$\tau_{k,uncr}$	psi (MPa)	1,540 (10.6)	1,540 (10.6)	1,540 (10.6)	1,540 (10.6)	1,540 (10.6)	1,540 (10.6)	1,540 (10.6)
Temperature range C <sup>2</sup>	Characteristic bond strength in cracked concrete	$\tau_{k,cr}$	psi (MPa)	730 (5.0)	735 (5.1)	740 (5.1)	745 (5.1)	630 (4.3)	635 (4.4)	635 (4.4)
	Characteristic bond strength in uncracked concrete	$\tau_{k,uncr}$	psi (MPa)	1,315 (9.1)	1,315 (9.1)	1,315 (9.1)	1,315 (9.1)	1,315 (9.1)	1,315 (9.1)	1,315 (9.1)
Permissible installation conditions	Dry concrete	Anchor Category	-	1						
		$\phi_d$	-	0.65						
	Water saturated concrete	Anchor Category	-	2						
		$\phi_{ws}$	-	0.55						
Reduction for seismic tension		$\alpha_{N,seis}$	-	0.8			1.0			

For SI: 1 inch ≡ 25.4 mm, 1 lbf = 4.448 N, 1 psi = 0.006897 MPa.  
 For pound-inch units: 1 mm = 0.03937 inches, 1 N = 0.2248 lbf, 1 MPa = 145.0 psi

<sup>1</sup> Bond strength values correspond to concrete compressive strength  $f'_c = 2,500$  psi (17.2 MPa). For concrete compressive strength,  $f'_c$ , between 2,500 psi (17.2 MPa) and 8,000 psi (55.2 MPa), the tabulated characteristic bond strength may be increased by a factor of  $(f'_c / 2,500)^{0.1}$  [For SI:  $(f'_c / 17.2)^{0.1}$ ]. See Section 4.1.4 of this report for bond strength determination.

<sup>2</sup> Temperature range A: Maximum short term temperature = 130°F (55°C), Maximum long term temperature = 110°F (43°C).  
 Temperature range B: Maximum short term temperature = 176°F (80°C), Maximum long term temperature = 110°F (43°C).  
 Temperature range C: Maximum short term temperature = 248°F (120°C), Maximum long term temperature = 162°F (72°C).  
 Short term elevated concrete temperatures are those that occur over brief intervals, e.g., as a result of diurnal cycling. Long term concrete temperatures are roughly constant over significant periods of time.



TABLE 15—STEEL DESIGN INFORMATION FOR METRIC THREADED ROD AND EU METRIC REINFORCING BARS

DESIGN INFORMATION		Symbol	Units	Nominal rod diameter (mm) <sup>1</sup>							
				10	12	16	20	24	27	30	
Rod Outside Diameter		<i>d</i>	mm (in.)	10 (0.39)	12 (0.47)	16 (0.63)	20 (0.79)	24 (0.94)	27 (1.06)	30 (1.18)	
Rod effective cross-sectional area		<i>A<sub>se</sub></i>	mm <sup>2</sup> (in. <sup>2</sup> )	58.0 (0.090)	84.3 (0.131)	157 (0.243)	245 (0.380)	353 (0.547)	459 (0.711)	561 (0.870)	
ISO 898-1 Class 5.8	Nominal strength as governed by steel strength	<i>N<sub>sa</sub></i>	kN (lb)	29.0 (6,519)	42.0 (9,476)	78.5 (17,647)	122.5 (27,539)	176.5 (39,679)	229.5 (51,594)	280.5 (63,059)	
		<i>V<sub>sa</sub></i>	kN (lb)	14.5 (3,260)	25.5 (5,685)	47.0 (10,588)	73.5 (16,523)	106.0 (23,807)	137.5 (30,956)	168.5 (37,835)	
	Reduction for seismic shear	<i>α<sub>V,seis</sub></i>	-	0.70							
	Strength reduction factor for tension <sup>2</sup>	<i>φ</i>	-	0.65							
	Strength reduction factor for shear <sup>2</sup>	<i>φ</i>	-	0.60							
ISO 898-1 Class 8.8	Nominal strength as governed by steel strength	<i>N<sub>sa</sub></i>	kN (lb)	46.5 (10,431)	67.5 (15,161)	125.5 (28,236)	196.0 (44,063)	282.5 (63,486)	367.0 (82,550)	449.0 (100,894)	
		<i>V<sub>sa</sub></i>	kN (lb)	23.0 (5,216)	40.5 (9,097)	75.5 (16,942)	117.5 (26,438)	169.5 (38,092)	220.5 (49,530)	269.5 (60,537)	
	Reduction for seismic shear	<i>α<sub>V,seis</sub></i>	-	0.70							
	Strength reduction factor for tension <sup>2</sup>	<i>φ</i>	-	0.65							
	Strength reduction factor for shear <sup>2</sup>	<i>φ</i>	-	0.60							
ISO 3506-1 Class A4 Stainless <sup>3</sup>	Nominal strength as governed by steel strength	<i>N<sub>sa</sub></i>	kN (lb)	40.6 (9,127)	59.0 (13,266)	109.9 (24,706)	171.5 (38,555)	247.1 (55,550)	183.1 (41,172)	223.8 (50,321)	
		<i>V<sub>sa</sub></i>	kN (lb)	20.3 (4,564)	35.4 (7,960)	65.9 (14,824)	102.9 (23,133)	148.3 (33,330)	109.9 (24,703)	134.3 (30,192)	
	Reduction for seismic shear	<i>α<sub>V,seis</sub></i>	-	0.70							
	Strength reduction factor for tension <sup>2</sup>	<i>φ</i>	-	0.65							
	Strength reduction factor for shear <sup>2</sup>	<i>φ</i>	-	0.60							
DESIGN INFORMATION		Symbol	Units	Reinforcing bar size							
Nominal bar diameter		<i>d</i>	mm (in.)	10.0 (0.394)	12.0 (0.472)	14.0 (0.551)	16.0 (0.630)	20.0 (0.787)	25.0 (0.984)	28.0 (1.102)	32.0 (1.260)
Bar effective cross-sectional area		<i>A<sub>se</sub></i>	mm <sup>2</sup> (in. <sup>2</sup> )	78.5 (0.122)	113.1 (0.175)	153.9 (0.239)	201.1 (0.312)	314.2 (0.487)	490.9 (0.761)	615.8 (0.954)	804.2 (1.247)
DIN 488 BSt 550/500	Nominal strength as governed by steel strength	<i>N<sub>sa</sub></i>	kN (lb)	43.0 (9,711)	62.0 (13,984)	84.5 (19,034)	110.5 (24,860)	173.0 (38,844)	270.0 (60,694)	338.5 (76,135)	442.5 (99,441)
		<i>V<sub>sa</sub></i>	kN (lb)	26.0 (5,827)	37.5 (8,390)	51.0 (11,420)	66.5 (14,916)	103.0 (23,307)	162.0 (36,416)	203.0 (45,681)	265.5 (59,665)
	Reduction for seismic shear	<i>α<sub>V,seis</sub></i>	-	0.70							
	Strength reduction factor for tension <sup>2</sup>	<i>φ</i>	-	0.65							
	Strength reduction factor for shear <sup>2</sup>	<i>φ</i>	-	0.60							

For SI: 1 inch ≡ 25.4 mm, 1 lbf = 4.448 N, 1 psi = 0.006897 MPa.  
 For pound-inch units: 1 mm = 0.03937 inches, 1 N = 0.2248 lbf, 1 MPa = 145.0 psi

<sup>1</sup> Values provided for common rod material types are based on specified strengths and calculated in accordance with ACI 318-11 Eq. (D-2) and Eq. (D-29). Nuts and washers must be appropriate for the rod.

<sup>2</sup> For use with the load combinations of IBC Section 1605.2 or ACI 318-11 Section 9.2, as set forth in ACI 318-11 D.4.3. If the load combinations of ACI 318-11 Appendix C are used, the appropriate value of *φ* must be determined in accordance with ACI 318-11 D.4.4. Values correspond to a brittle steel element.

<sup>3</sup> A4-70 Stainless (M8- M24); A4-502 Stainless (M27- M30)



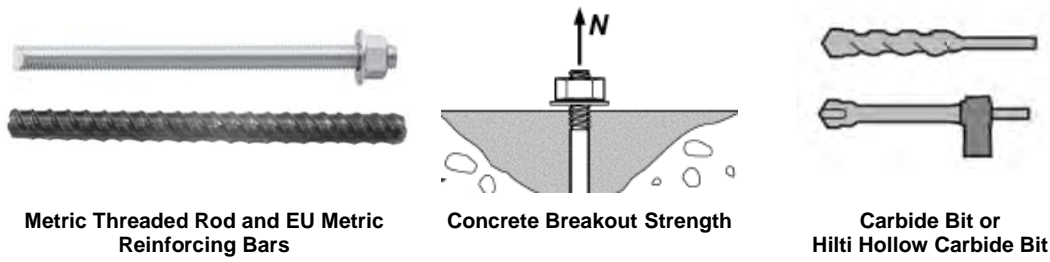
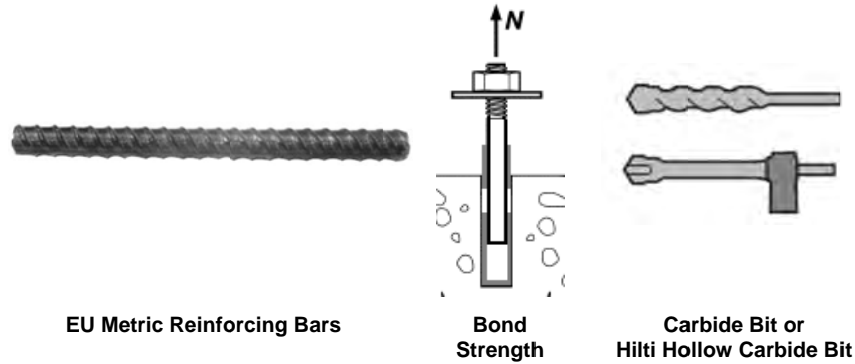

**TABLE 16—CONCRETE BREAKOUT DESIGN INFORMATION FOR METRIC THREADED ROD AND EU METRIC REINFORCING BARS IN HOLES DRILLED WITH A HAMMER DRILL AND CARBIDE BIT (OR HILTI HOLLOW CARBIDE DRILL BIT)<sup>1</sup>**

DESIGN INFORMATION	Symbol	Units	Nominal rod diameter (mm)							
			10	12	16	20	24	27	30	
Minimum Embedment	$h_{ef,min}$	mm (in.)	60 (2.4)	70 (2.8)	80 (3.1)	90 (3.5)	96 (3.8)	108 (4.3)	120 (4.7)	
Maximum Embedment	$h_{ef,max}$	mm (in.)	200 (7.9)	240 (9.4)	320 (12.6)	400 (15.7)	480 (18.9)	540 (21.3)	600 (23.6)	
Min. anchor spacing <sup>3</sup>	$s_{min}$	mm (in.)	50 (2.0)	60 (2.4)	80 (3.2)	100 (3.9)	120 (4.7)	135 (5.3)	150 (5.9)	
Min. edge distance <sup>3</sup>	$c_{min}$	-	5d; or see Section 4.1.9.2 of this report for design with reduced minimum edge distances							
Minimum concrete thickness	$h_{min}$	mm (in.)	$h_{ef} + 30$ ( $h_{ef} + 1\frac{1}{4}$ )	$h_{ef} + 2d_o^{(4)}$						
DESIGN INFORMATION	Symbol	Units	Reinforcing bar size							
			10	12	14	16	20	25	28	32
Minimum Embedment	$h_{ef,min}$	mm (in.)	60 (2.4)	70 (2.8)	75 (3.0)	80 (3.1)	90 (3.5)	100 (3.9)	112 (4.4)	128 (5.0)
Maximum Embedment	$h_{ef,max}$	mm (in.)	200 (7.9)	240 (9.4)	280 (11.0)	320 (12.6)	400 (15.7)	500 (19.7)	560 (22.0)	640 (25.2)
Min. anchor spacing <sup>3</sup>	$s_{min}$	mm (in.)	50 (2.0)	60 (2.4)	80 (3.2)	100 (3.9)	120 (4.7)	135 (5.3)	140 (5.5)	160 (6.3)
Min. edge distance <sup>3</sup>	$c_{min}$	-	5d; or see Section 4.1.9 of this report for design with reduced minimum edge distances							
Minimum concrete thickness	$h_{min}$	mm (in.)	$h_{ef} + 30$ ( $h_{ef} + 1\frac{1}{4}$ )	$h_{ef} + 2d_o^{(4)}$						
Critical edge distance – splitting (for uncracked concrete)	$c_{ac}$	-	See Section 4.1.10.2 of this report.							
Effectiveness factor for cracked concrete	$k_{c,cr}$	SI (in-lb)	7.1 (17)							
Effectiveness factor for uncracked concrete	$k_{c,uncr}$	SI (in-lb)	10 (24)							
Strength reduction factor for tension, concrete failure modes, Condition B <sup>2</sup>	$\phi$	-	0.65							
Strength reduction factor for shear, concrete failure modes, Condition B <sup>2</sup>	$\phi$	-	0.70							

For SI: 1 inch ≅ 25.4 mm, 1 lbf = 4.448 N, 1 psi = 0.006897 MPa.  
 For pound-inch units: 1 mm = 0.03937 inches, 1 N = 0.2248 lbf, 1 MPa = 145.0 psi

<sup>1</sup> Additional setting information is described in Figure 9, Manufacturers Printed Installation Instructions (MPII).  
<sup>2</sup> Values provided for post-installed anchors installed under Condition B without supplementary reinforcement as defined in ACI 318-11 D.4.3.  
<sup>3</sup> For installations with 1<sup>3</sup>/<sub>4</sub>-inch edge distance, refer to Section 4.1.9.2 for spacing and maximum torque requirements.  
<sup>4</sup>  $d_o$  = hole diameter.



**TABLE 17—BOND STRENGTH DESIGN INFORMATION FOR EU METRIC REINFORCING BARS IN HOLES DRILLED WITH A HAMMER DRILL AND CARBIDE BIT (OR HILTI HOLLOW CARBIDE DRILL BIT)<sup>1</sup>**

DESIGN INFORMATION		Symbol	Units	Reinforcing bar size							
				10	12	14	16	20	25	28	32
Minimum Embedment		$h_{ef,min}$	mm (in.)	60 (2.4)	70 (2.8)	75 (3.0)	80 (3.1)	90 (3.5)	100 (3.9)	112 (4.4)	128 (5.0)
Maximum Embedment		$h_{ef,max}$	mm (in.)	200 (7.9)	240 (9.4)	280 (11.0)	320 (12.6)	400 (15.7)	500 (19.7)	560 (22.0)	640 (25.2)
Temperature range A <sup>2</sup>	Characteristic bond strength in cracked concrete	$\tau_{k,cr}$	MPa (psi)	7.4 (1,075)	7.5 (1,080)	7.5 (1,085)	7.5 (1,090)	7.5 (1,095)	5.8 (840)	5.8 (845)	5.9 (850)
	Characteristic bond strength in uncracked concrete	$\tau_{k,uncr}$	MPa (psi)	10.8 (1,560)	10.8 (1,560)	10.8 (1,560)	10.8 (1,560)	10.8 (1,560)	10.8 (1,560)	10.8 (1,560)	10.8 (1,560)
Temperature range B <sup>2</sup>	Characteristic bond strength in cracked concrete	$\tau_{k,cr}$	MPa (psi)	6.8 (990)	6.9 (995)	6.9 (995)	6.9 (1000)	6.9 (1005)	5.3 (770)	5.4 (775)	5.4 (785)
	Characteristic bond strength in uncracked concrete	$\tau_{k,uncr}$	MPa (psi)	9.9 (1,435)	9.9 (1,435)	9.9 (1,435)	9.9 (1,435)	9.9 (1,435)	9.9 (1,435)	9.9 (1,435)	9.9 (1,435)
Temperature range C <sup>2</sup>	Characteristic bond strength in cracked concrete	$\tau_{k,cr}$	MPa (psi)	5.8 (845)	5.9 (850)	5.9 (850)	5.9 (855)	5.9 (860)	4.6 (660)	4.6 (665)	4.6 (670)
	Characteristic bond strength in uncracked concrete	$\tau_{k,uncr}$	MPa (psi)	8.5 (1,230)	8.5 (1,230)	8.5 (1,230)	8.5 (1,230)	8.5 (1,230)	8.5 (1,230)	8.5 (1,230)	8.5 (1,230)
Permissible Installation Conditions	Dry concrete	Anchor Category	-	1							
		$\phi_d$	-	0.65							
	Water saturated concrete	Anchor Category	-	2							
		$\phi_{ws}$	-	0.55							
Reduction for seismic tension		$\alpha_{N,seis}$	-	0.8					0.85	0.90	1.00

For SI: 1 inch = 25.4 mm, 1 lbf = 4.448 N, 1 psi = 0.006897 MPa.  
 For pound-inch units: 1 mm = 0.03937 inches, 1 N = 0.2248 lbf, 1 MPa = 145.0 psi

<sup>1</sup> Bond strength values correspond to concrete compressive strength  $f'_c = 2,500$  psi (17.2 MPa). For concrete compressive strength,  $f'_c$ , between 2,500 psi (17.2 MPa) and 8,000 psi (55.2 MPa), the tabulated characteristic bond strength may be increased by a factor of  $(f'_c / 2,500)^{0.1}$  [For SI:  $(f'_c / 17.2)^{0.1}$ ]. See Section 4.1.4 of this report for bond strength determination.

<sup>2</sup> Temperature range A: Maximum short term temperature = 130°F (55°C), Maximum long term temperature = 110°F (43°C).  
 Temperature range B: Maximum short term temperature = 176°F (80°C), Maximum long term temperature = 110°F (43°C).  
 Temperature range C: Maximum short term temperature = 248°F (120°C), Maximum long term temperature = 162°F (72°C).  
 Short term elevated concrete temperatures are those that occur over brief intervals, e.g., as a result of diurnal cycling. Long term concrete temperatures are roughly constant over significant periods of time.

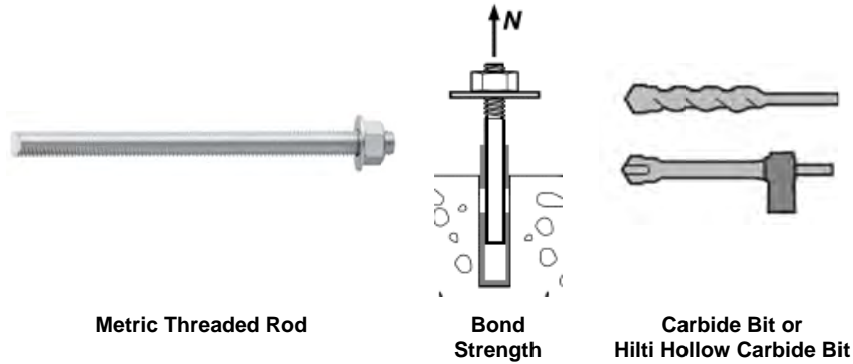

**TABLE 18—BOND STRENGTH DESIGN INFORMATION FOR METRIC THREADED ROD IN HOLES DRILLED WITH A HAMMER DRILL AND CARBIDE BIT (OR HILTI HOLLOW CARBIDE DRILL BIT)<sup>1</sup>**

DESIGN INFORMATION		Symbol	Units	Nominal rod diameter (mm)						
				10	12	16	20	24	27	30
Minimum Embedment		$h_{ef,min}$	mm (in.)	60 (2.4)	70 (2.8)	80 (3.1)	90 (3.5)	96 (3.8)	108 (4.3)	120 (4.7)
Maximum Embedment		$h_{ef,max}$	mm (in.)	200 (7.9)	240 (9.4)	320 (12.6)	400 (15.7)	480 (18.9)	540 (21.3)	600 (23.6)
Temperature range A <sup>2</sup>	Characteristic bond strength in cracked concrete	$\tau_{k,cr}$	MPa (psi)	6.4 (930)	6.4 (935)	6.5 (940)	6.5 (945)	5.5 (800)	5.6 (805)	5.6 (810)
	Characteristic bond strength in uncracked concrete	$\tau_{k,uncr}$	MPa (psi)	11.5 (1,670)	11.5 (1,670)	11.5 (1,670)	11.5 (1,670)	11.5 (1,670)	11.5 (1,670)	11.5 (1,670)
Temperature range B <sup>2</sup>	Characteristic bond strength in cracked concrete	$\tau_{k,cr}$	MPa (psi)	5.9 (855)	5.9 (860)	6.0 (865)	6.0 (870)	5.1 (740)	5.1 (740)	5.1 (745)
	Characteristic bond strength in uncracked concrete	$\tau_{k,uncr}$	MPa (psi)	10.6 (1,540)	10.6 (1,540)	10.6 (1,540)	10.6 (1,540)	10.6 (1,540)	10.6 (1,540)	10.6 (1,540)
Temperature range C <sup>2</sup>	Characteristic bond strength in cracked concrete	$\tau_{k,cr}$	MPa (psi)	5.0 (730)	5.1 (735)	5.1 (740)	5.1 (745)	4.4 (630)	4.4 (635)	4.4 (635)
	Characteristic bond strength in uncracked concrete	$\tau_{k,uncr}$	MPa (psi)	9.1 (1,315)	9.1 (1,315)	9.1 (1,315)	9.1 (1,315)	9.1 (1,315)	9.1 (1,315)	9.1 (1,315)
Permissible Installation Conditions	Dry concrete	Anchor Category	-	1						
		$\phi_d$	-	0.65						
	Water saturated concrete	Anchor Category	-	2						
		$\phi_{ws}$	-	0.55						
Reduction for seismic tension		$\alpha_{N,seis}$	-	0.8				1.0		

For SI: 1 inch ≅ 25.4 mm, 1 lbf = 4.448 N, 1 psi = 0.006897 MPa.  
 For pound-inch units: 1 mm = 0.03937 inches, 1 N = 0.2248 lbf, 1 MPa = 145.0 psi

<sup>1</sup> Bond strength values correspond to concrete compressive strength  $f_c = 2,500$  psi (17.2 MPa). For concrete compressive strength,  $f_c$ , between 2,500 psi (17.2 MPa) and 8,000 psi (55.2 MPa), the tabulated characteristic bond strength may be increased by a factor of  $(f_c / 2,500)^{0.1}$  [For SI:  $(f_c / 17.2)^{0.1}$ ]. See Section 4.1.4 of this report for bond strength determination.

<sup>2</sup> Temperature range A: Maximum short term temperature = 130°F (55°C), Maximum long term temperature = 110°F (43°C).  
 Temperature range B: Maximum short term temperature = 176°F (80°C), Maximum long term temperature = 110°F (43°C).  
 Temperature range C: Maximum short term temperature = 248°F (120°C), Maximum long term temperature = 162°F (72°C).  
 Short term elevated concrete temperatures are those that occur over brief intervals, e.g., as a result of diurnal cycling. Long term concrete temperatures are roughly constant over significant periods of time.



TABLE 19—STEEL DESIGN INFORMATION FOR CANADIAN METRIC REINFORCING BARS

DESIGN INFORMATION		Symbol	Units	Bar size				
				10 M	15 M	20 M	25 M	30 M
Nominal bar diameter		$d$	mm (in.)	11.3 (0.445)	16.0 (0.630)	19.5 (0.768)	25.2 (0.992)	29.9 (1.177)
Bar effective cross-sectional area		$A_{se}$	mm <sup>2</sup> (in. <sup>2</sup> )	100.3 (0.155)	201.1 (0.312)	298.6 (0.463)	498.8 (0.773)	702.2 (1.088)
CSA G30	Nominal strength as governed by steel strength	$N_{sa}$	kN (lb)	54.0 (12,175)	108.5 (24,408)	161.5 (36,255)	270.0 (60,548)	380.0 (85,239)
		$V_{sa}$	kN (lb)	32.5 (7,305)	65.0 (14,645)	97.0 (21,753)	161.5 (36,329)	227.5 (51,144)
	Reduction for seismic shear	$\alpha_{V,seis}$	-	0.70				
	Strength reduction factor for tension <sup>1</sup>	$\phi$	-	0.65				
	Strength reduction factor for shear <sup>1</sup>	$\phi$	-	0.60				

For SI: 1 inch ≅ 25.4 mm, 1 lbf = 4.448 N, 1 psi = 0.006897 MPa.  
 For pound-inch units: 1 mm = 0.03937 inches, 1 N = 0.2248 lbf, 1 MPa = 145.0 psi

<sup>1</sup> For use with the load combinations of ACI 318-11 Section 9.2, as set forth in ACI 318-11 Section D.4.3. Values correspond to a brittle steel element.

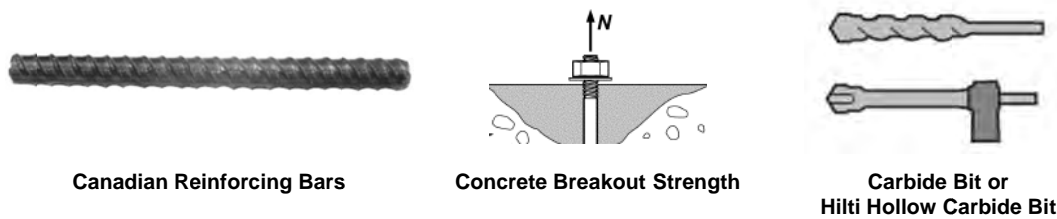
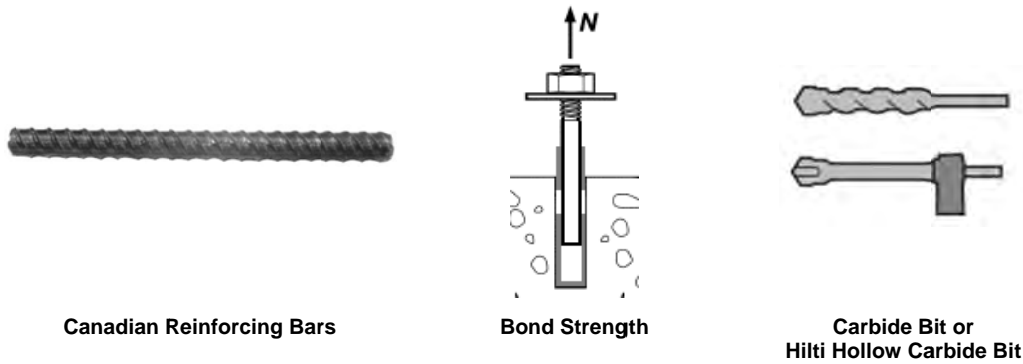

TABLE 20—CONCRETE BREAKOUT DESIGN INFORMATION FOR CANADIAN METRIC REINFORCING BARS IN HOLES DRILLED WITH A HAMMER DRILL AND CARBIDE BIT (OR HILTI HOLLOW CARBIDE DRILL BIT)<sup>1</sup>

DESIGN INFORMATION		Symbol	Units	Bar size				
				10 M	15 M	20 M	25 M	30 M
Effectiveness factor for cracked concrete		$k_{c,cr}$	SI (in-lb)	7.1 (17)				
Effectiveness factor for uncracked concrete		$k_{c,uncr}$	SI (in-lb)	10 (24)				
Minimum Embedment		$h_{ef,min}$	mm (in.)	70 (2.8)	80 (3.1)	90 (3.5)	101 (4.0)	120 (4.7)
Maximum Embedment		$h_{ef,max}$	mm (in.)	226 (8.9)	320 (12.6)	390 (15.4)	504 (19.8)	598 (23.5)
Min. bar spacing <sup>3</sup>		$s_{min}$	mm (in.)	57 (2.2)	80 (3.1)	98 (3.8)	126 (5.0)	150 (5.9)
Min. edge distance <sup>3</sup>		$c_{min}$	mm (in.)	5d; or see Section 4.1.9.2 of this report for design with reduced minimum edge distances				
Minimum concrete thickness		$h_{min}$	mm (in.)	$h_{ef} + 30$ ( $h_{ef} + 1\frac{1}{4}$ )	$h_{ef} + 2d_o^{(4)}$			
Critical edge distance – splitting (for uncracked concrete)		$c_{ac}$	-	See Section 4.1.10.2 of this report.				
Strength reduction factor for tension, concrete failure modes, Condition B <sup>2</sup>		$\phi$	-	0.65				
Strength reduction factor for shear, concrete failure modes, Condition B <sup>2</sup>		$\phi$	-	0.70				

For SI: 1 inch ≅ 25.4 mm, 1 lbf = 4.448 N, 1 psi = 0.006897 MPa.  
 For pound-inch units: 1 mm = 0.03937 inches, 1 N = 0.2248 lbf, 1 MPa = 145.0 psi

<sup>1</sup> Additional setting information is described in Figure 9, Manufacturers Printed Installation Instructions (MPII).  
<sup>2</sup> Values provided for post-installed set anchors installed under Condition B without supplementary reinforcement.  
<sup>3</sup> For installations with 1<sup>3</sup>/<sub>4</sub>-inch edge distance, refer to Section 4.1.9.2 for spacing and maximum torque requirements.  
<sup>4</sup>  $d_o$  = hole diameter.



**TABLE 21—BOND STRENGTH DESIGN INFORMATION FOR CANADIAN METRIC REINFORCING BARS IN HOLES DRILLED WITH A HAMMER DRILL AND CARBIDE BIT (OR HILTI HOLLOW CARBIDE DRILL BIT)<sup>1</sup>**

DESIGN INFORMATION		Symbol	Units	Bar size				
				10 M	15 M	20 M	25 M	30 M
Minimum Embedment		$h_{ef,min}$	mm (in.)	70 (2.8)	80 (3.1)	90 (3.5)	101 (4.0)	120 (4.7)
Maximum Embedment		$h_{ef,max}$	mm (in.)	226 (8.9)	320 (12.6)	390 (15.4)	504 (19.8)	598 (23.5)
Temperature range A <sup>2</sup>	Characteristic bond strength in cracked concrete	$\tau_{k,cr}$	MPa (psi)	7.4 (1,075)	7.5 (1,085)	7.5 (1,095)	5.8 (840)	5.9 (850)
	Characteristic bond strength in uncracked concrete	$\tau_{k,uncr}$	MPa (psi)	10.8 (1,560)	10.8 (1,560)	10.8 (1,560)	10.8 (1,560)	10.8 (1,560)
Temperature range B <sup>2</sup>	Characteristic bond strength in cracked concrete	$\tau_{k,cr}$	MPa (psi)	6.8 (990)	6.9 (995)	6.9 (1005)	5.3 (775)	5.4 (780)
	Characteristic bond strength in uncracked concrete	$\tau_{k,uncr}$	MPa (psi)	9.9 (1,435)	9.9 (1,435)	9.9 (1,435)	9.9 (1,435)	9.9 (1,435)
Temperature range C <sup>2</sup>	Characteristic bond strength in cracked concrete	$\tau_{k,cr}$	MPa (psi)	5.8 (845)	5.9 (850)	5.9 (860)	4.6 (660)	4.6 (670)
	Characteristic bond strength in uncracked concrete	$\tau_{k,uncr}$	MPa (psi)	8.5 (1,230)	8.5 (1,230)	8.5 (1,230)	8.5 (1,230)	8.5 (1,230)
Permissible installation conditions	Dry concrete	Anchor Category	-	1				
		$\phi_d$	-	0.65				
	Water saturated concrete	Anchor Category	-	2				
		$\phi_{ws}$	-	0.55				
Reduction for seismic tension		$\alpha_{N,seis}$	-	0.8			0.85	0.97

For SI: 1 inch ≅ 25.4 mm, 1 lbf = 4.448 N, 1 psi = 0.006897 MPa.  
 For pound-inch units: 1 mm = 0.03937 inches, 1 N = 0.2248 lbf, 1 MPa = 145.0 psi

<sup>1</sup> Bond strength values correspond to concrete compressive strength  $f'_c = 2,500$  psi (17.2 MPa). For concrete compressive strength,  $f'_c$ , between 2,500 psi (17.2 MPa) and 8,000 psi (55.2 MPa), the tabulated characteristic bond strength may be increased by a factor of  $(f'_c / 2,500)^{0.1}$  [For SI:  $(f'_c / 17.2)^{0.1}$ ]. See Section 4.1.4 of this report for bond strength determination.

<sup>2</sup> Temperature range A: Maximum short term temperature = 130°F (55°C), Maximum long term temperature = 110°F (43°C).  
 Temperature range B: Maximum short term temperature = 176°F (80°C), Maximum long term temperature = 110°F (43°C).  
 Temperature range C: Maximum short term temperature = 248°F (120°C), Maximum long term temperature = 162°F (72°C).  
 Short term elevated concrete temperatures are those that occur over brief intervals, e.g., as a result of diurnal cycling. Long term concrete temperatures are roughly constant over significant periods of time.

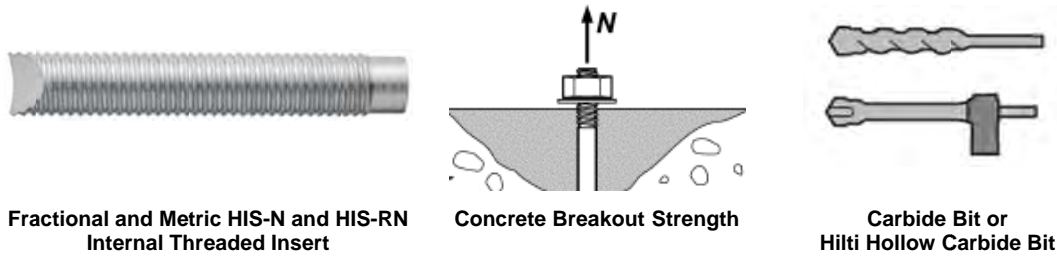

TABLE 22—STEEL DESIGN INFORMATION FOR FRACTIONAL AND METRIC HIS-N AND HIS-RN THREADED INSERTS<sup>1</sup>

DESIGN INFORMATION	Symbol	Units	Nominal Bolt/Cap Screw Diameter (in.) Fractional				Units	Nominal Bolt/Cap Screw Diameter (mm) Metric					
			<sup>3</sup> / <sub>8</sub>	<sup>1</sup> / <sub>2</sub>	<sup>5</sup> / <sub>8</sub>	<sup>3</sup> / <sub>4</sub>		8	10	12	16	20	
HIS Insert O.D.	<i>D</i>	in. (mm)	0.65 (16.5)	0.81 (20.5)	1.00 (25.4)	1.09 (27.6)	mm (in.)	12.5 (0.49)	16.5 (0.65)	20.5 (0.81)	25.4 (1.00)	27.6 (1.09)	
HIS insert length	<i>L</i>	in. (mm)	4.33 (110)	4.92 (125)	6.69 (170)	8.07 (205)	mm (in.)	90 (3.54)	110 (4.33)	125 (4.92)	170 (6.69)	205 (8.07)	
Bolt effective cross-sectional area	<i>A<sub>se</sub></i>	in. <sup>2</sup> (mm <sup>2</sup> )	0.0775 (50)	0.1419 (92)	0.2260 (146)	0.3345 (216)	mm <sup>2</sup> (in. <sup>2</sup> )	36.6 (0.057)	58 (0.090)	84.3 (0.131)	157 (0.243)	245 (0.380)	
HIS insert effective cross-sectional area	<i>A<sub>insert</sub></i>	in. <sup>2</sup> (mm <sup>2</sup> )	0.178 (115)	0.243 (157)	0.404 (260)	0.410 (265)	mm <sup>2</sup> (in. <sup>2</sup> )	51.5 (0.080)	108 (0.167)	169.1 (0.262)	256.1 (0.397)	237.6 (0.368)	
ASTM A193 B7	Nominal steel strength – ASTM A193 B7 <sup>3</sup> bolt/cap screw	<i>N<sub>sa</sub></i>	lb (kN)	9,690 (43.1)	17,740 (78.9)	28,250 (125.7)	41,815 (186.0)	kN (lb)	-	-	-	-	-
		<i>V<sub>sa</sub></i>	lb (kN)	5,815 (25.9)	10,645 (47.3)	16,950 (75.4)	25,090 (111.6)	kN (lb)	-	-	-	-	-
	Nominal steel strength – HIS-N insert	<i>N<sub>sa</sub></i>	lb (kN)	12,650 (56.3)	16,195 (72.0)	26,925 (119.8)	27,360 (121.7)	kN (lb)	-	-	-	-	-
ASTM A193 Grade B8M SS	Nominal steel strength – ASTM A193 Grade B8M SS bolt/cap screw	<i>N<sub>sa</sub></i>	lb (kN)	8,525 (37.9)	15,610 (69.4)	24,860 (110.6)	36,795 (163.7)	kN (lb)	-	-	-	-	-
		<i>V<sub>sa</sub></i>	lb (kN)	5,115 (22.8)	9,365 (41.7)	14,915 (66.3)	22,075 (98.2)	kN (lb)	-	-	-	-	-
	Nominal steel strength – HIS-RN insert	<i>N<sub>sa</sub></i>	lb (kN)	17,165 (76.3)	23,430 (104.2)	38,955 (173.3)	39,535 (175.9)	kN (lb)	-	-	-	-	-
ISO 898-1 Class 8.8	Nominal steel strength – ISO 898-1 Class 8.8 bolt/cap screw	<i>N<sub>sa</sub></i>	lb (kN)	-	-	-	-	kN (lb)	29.5 (6,582)	46.5 (10,431)	67.5 (15,161)	125.5 (28,236)	196.0 (44,063)
		<i>V<sub>sa</sub></i>	lb (kN)	-	-	-	-	kN (lb)	17.5 (3,949)	28.0 (6,259)	40.5 (9,097)	75.5 (16,942)	117.5 (26,438)
	Nominal steel strength – HIS-N insert	<i>N<sub>sa</sub></i>	lb (kN)	-	-	-	-	kN (lb)	25.0 (5,669)	53.0 (11,894)	78.0 (17,488)	118.0 (26,483)	110.0 (24,573)
ISO 3506-1 Class A4-70 Stainless	Nominal steel strength – ISO 3506-1 Class A4-70 Stainless bolt/cap screw	<i>N<sub>sa</sub></i>	lb (kN)	-	-	-	-	kN (lb)	25.5 (5,760)	40.5 (9,127)	59.0 (13,266)	110.0 (24,706)	171.5 (38,555)
		<i>V<sub>sa</sub></i>	lb (kN)	-	-	-	-	kN (lb)	15.5 (3,456)	24.5 (5,476)	35.5 (7,960)	66.0 (14,824)	103.0 (23,133)
	Nominal steel strength – HIS-RN insert	<i>N<sub>sa</sub></i>	lb (kN)	-	-	-	-	kN (lb)	36.0 (8,099)	75.5 (16,991)	118.5 (26,612)	179.5 (40,300)	166.5 (37,394)
Reduction for seismic shear	<i>α<sub>V,seis</sub></i>	-	0.70				-	0.70					
Strength reduction factor for tension <sup>2</sup>	<i>φ</i>	-	0.65				-	0.65					
Strength reduction factor for shear <sup>2</sup>	<i>φ</i>	-	0.60				-	0.60					

For **SI**: 1 inch ≡ 25.4 mm, 1 lbf = 4.448 N, 1 psi = 0.006897MPa.  
 For pound-inch units: 1 mm = 0.03937 inches, 1 N = 0.2248 lbf, 1 MPa = 145.0 psi

<sup>1</sup> Values provided for common rod material types based on specified strengths and calculated in accordance with ACI 318-11 Eq. (D-2) and Eq. (D-29). Nuts and washers must be appropriate for the rod.  
<sup>2</sup> For use with the load combinations of ACI 318-11 9.2, as set forth in ACI 318-11 D.4.3. Values correspond to a brittle steel element for the HIS insert.  
<sup>3</sup> For the calculation of the design steel strength in tension and shear for the bolt or screw, the *φ* factor for ductile steel failure according to ACI 318-11 D.4.3 can be used.

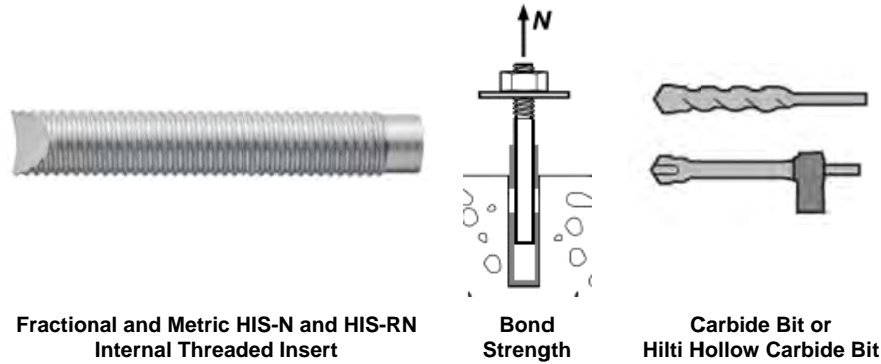

**TABLE 23—CONCRETE BREAKOUT DESIGN INFORMATION FOR FRACTIONAL AND METRIC HILTI HIS-N AND HIS-RN INSERTS IN HOLES DRILLED WITH A HAMMER DRILL AND CARBIDE BIT (OR HILTI HOLLOW CARBIDE DRILL BIT)<sup>1</sup>**

DESIGN INFORMATION	Symbol	Units	Nominal Bolt/Cap Screw Diameter (in.) Fractional				Units	Nominal Bolt/Cap Screw Diameter (mm) Metric				
			<sup>3</sup> / <sub>8</sub>	<sup>1</sup> / <sub>2</sub>	<sup>5</sup> / <sub>8</sub>	<sup>3</sup> / <sub>4</sub>		8	10	12	16	20
Effectiveness factor for cracked concrete	$k_{c,cr}$	in-lb (SI)	17 (7.1)				SI (in-lb)	7.1 (17)				
Effectiveness factor for uncracked concrete	$k_{c,uncr}$	in-lb (SI)	24 (10)				SI (in-lb)	10 (24)				
Effective embedment depth	$h_{ef}$	in. (mm)	$4^{3}/_8$ (110)	5 (125)	$6^{3}/_4$ (170)	$8^{1}/_8$ (205)	mm (in.)	90 (3.5)	110 (4.3)	125 (4.9)	170 (6.7)	205 (8.1)
Min. anchor spacing <sup>3</sup>	$s_{min}$	in. (mm)	$3^{1}/_4$ (83)	4 (102)	5 (127)	$5^{1}/_2$ (140)	mm (in.)	63 (2.5)	83 (3.25)	102 (4.0)	127 (5.0)	140 (5.5)
Min. edge distance <sup>3</sup>	$c_{min}$	in. (mm)	$3^{1}/_4$ (83)	4 (102)	5 (127)	$5^{1}/_2$ (140)	mm (in.)	63 (2.5)	83 (3.25)	102 (4.0)	127 (5.0)	140 (5.5)
Minimum concrete thickness	$h_{min}$	in. (mm)	5.9 (150)	6.7 (170)	9.1 (230)	10.6 (270)	mm (in.)	120 (4.7)	150 (5.9)	170 (6.7)	230 (9.1)	270 (10.6)
Critical edge distance – splitting (for uncracked concrete)	$c_{ac}$	-	See Section 4.1.10.2 of this report				-	See Section 4.1.10.2 of this report				
Strength reduction factor for tension, concrete failure modes, Condition B <sup>2</sup>	$\phi$	-	0.65				-	0.65				
Strength reduction factor for shear, concrete failure modes, Condition B <sup>2</sup>	$\phi$	-	0.70				-	0.70				

For SI: 1 inch ≅ 25.4 mm, 1 lbf = 4.448 N, 1 psi = 0.006897MPa.  
 For pound-inch units: 1 mm = 0.03937 inches, 1 N = 0.2248 lbf, 1 MPa = 145.0 psi

<sup>1</sup> Additional setting information is described in Figure 9, Manufacturers Printed Installation Instructions (MPII).  
<sup>2</sup> Values provided for post-installed anchors installed under Condition B without supplementary reinforcement as defined in ACI 318-11 D.4.3.  
<sup>3</sup> For installations with  $1^{3}/_4$ -inch edge distance, refer to Section 4.1.9.2 for spacing and maximum torque requirements.



**TABLE 24—BOND STRENGTH DESIGN INFORMATION FOR FRACTIONAL AND METRIC HILTI HIS-N AND HIS-RN INSERTS IN HOLES DRILLED WITH A HAMMER DRILL AND CARBIDE BIT (OR HILTI HOLLOW CARBIDE DRILL BIT)<sup>1</sup>**

DESIGN INFORMATION	Symbol	Units	Nominal Bolt/Cap Screw Diameter (in.) Fractional				Units	Nominal Bolt/Cap Screw Diameter (mm) Metric					
			<sup>3</sup> / <sub>8</sub>	<sup>1</sup> / <sub>2</sub>	<sup>5</sup> / <sub>8</sub>	<sup>3</sup> / <sub>4</sub>		8	10	12	16	20	
			mm	mm	mm	mm		mm	mm	mm	mm	mm	
Effective embedment depth	$h_{ef}$	in. (mm)	4 <sup>3</sup> / <sub>8</sub> (110)	5 (125)	6 <sup>3</sup> / <sub>4</sub> (170)	8 <sup>1</sup> / <sub>8</sub> (205)	mm (in.)	90 (3.5)	110 (4.3)	125 (4.9)	170 (6.7)	205 (8.1)	
HIS Insert O.D.	$D$	in. (mm)	0.65 (16.5)	0.81 (20.5)	1.00 (25.4)	1.09 (27.6)	mm (in.)	12.5 (0.49)	16.5 (0.65)	20.5 (0.81)	25.4 (1.00)	27.6 (1.09)	
Temperature range A <sup>2</sup>	Characteristic bond strength in cracked concrete	$\tau_{k,cr}$	psi (MPa)	940 (6.5)	950 (6.5)	805 (5.5)	805 (5.5)	MPa (psi)	6.4 (935)	6.5 (940)	6.5 (950)	5.5 (805)	5.6 (805)
	Characteristic bond strength in uncracked concrete	$\tau_{k,uncr}$	psi (MPa)	1,670 (11.5)	1,670 (11.5)	1,670 (11.5)	1,670 (11.5)	MPa (psi)	11.5 (1,670)	11.5 (1,670)	11.5 (1,670)	11.5 (1,670)	11.5 (1,670)
Temperature range B <sup>2</sup>	Characteristic bond strength in cracked concrete	$\tau_{k,cr}$	psi (MPa)	865 (6.0)	870 (6.0)	740 (5.1)	740 (5.1)	MPa (psi)	5.9 (860)	6.0 (865)	6.0 (870)	5.1 (740)	5.1 (740)
	Characteristic bond strength in uncracked concrete	$\tau_{k,uncr}$	psi (MPa)	1,540 (10.6)	1,540 (10.6)	1,540 (10.6)	1,540 (10.6)	MPa (psi)	10.6 (1,540)	10.6 (1,540)	10.6 (1,540)	10.6 (1,540)	10.6 (1,540)
Temperature range C <sup>2</sup>	Characteristic bond strength in cracked concrete	$\tau_{k,cr}$	psi (MPa)	740 (5.1)	745 (5.1)	635 (4.4)	635 (4.4)	MPa (psi)	5.1 (735)	5.1 (740)	5.1 (745)	4.4 (635)	4.4 (635)
	Characteristic bond strength in uncracked concrete	$\tau_{k,uncr}$	psi (MPa)	1,315 (9.1)	1,315 (9.1)	1,315 (9.1)	1,315 (9.1)	MPa (psi)	9.1 (1,315)	9.1 (1,315)	9.1 (1,315)	9.1 (1,315)	9.1 (1,315)
Permissible installation conditions	Dry concrete	Anchor Category	-	1				-	1				
		$\phi_d$	-	0.65				-	0.65				
	Water saturated concrete	Anchor Category	-	2				-	2				
		$\phi_{ws}$	-	0.55				-	0.55				
Reduction for seismic tension	$\alpha_{N,seis}$	-	0.8				-	0.8					

For SI: 1 inch ≅ 25.4 mm, 1 lbf = 4.448 N, 1 psi = 0.006897 MPa.  
 For pound-inch units: 1 mm = 0.03937 inches, 1 N = 0.2248 lbf, 1 MPa = 145.0 psi

<sup>1</sup> Bond strength values correspond to concrete compressive strength  $f'_c = 2,500$  psi (17.2 MPa). For concrete compressive strength,  $f'_c$ , between 2,500 psi (17.2 MPa) and 8,000 psi (55.2 MPa), the tabulated characteristic bond strength may be increased by a factor of  $(f'_c / 2,500)^{0.1}$  [For SI:  $(f'_c / 17.2)^{0.1}$ ]. See Section 4.1.4 of this report for bond strength determination.

<sup>2</sup> Temperature range A: Maximum short term temperature = 130°F (55°C), Maximum long term temperature = 110°F (43°C).  
 Temperature range B: Maximum short term temperature = 176°F (80°C), Maximum long term temperature = 110°F (43°C).  
 Temperature range C: Maximum short term temperature = 248°F (120°C), Maximum long term temperature = 162°F (72°C).  
 Short term elevated concrete temperatures are those that occur over brief intervals, e.g., as a result of diurnal cycling. Long term concrete temperatures are roughly constant over significant periods of time.





HILTI HIT-HY 200 FOIL PACK AND MIXING NOZZLE



HILTI DISPENSER

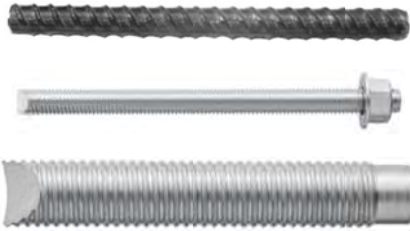

ANCHORING ELEMENTS



HILTI TE-CD OR TE-YD HOLLOW CARBIDE DRILL BIT

FIGURE 6—HILTI HIT-HY 200 ANCHORING SYSTEM

TABLE 25—DEVELOPMENT LENGTH FOR U.S. CUSTOMARY UNIT REINFORCING BARS IN HOLES DRILLED WITH A HAMMER DRILL AND CARBIDE BIT OR HILTI HOLLOW CARBIDE BIT<sup>1, 2, 4</sup>

DESIGN INFORMATION	Symbol	Criteria Section of Reference Standard	Units	Bar size							
				#3	#4	#5	#6	#7	#8	#9	#10
Nominal reinforcing bar diameter	$d_b$	ASTM A615/A706	in. (mm)	0.375 (9.5)	0.500 (12.7)	0.625 (15.9)	0.750 (19.1)	0.875 (22.2)	1.000 (25.4)	1.125 (28.6)	1.250 (31.8)
Nominal bar area	$A_b$	ASTM A615/A706	in <sup>2</sup> (mm <sup>2</sup> )	0.11 (71.3)	0.20 (126.7)	0.31 (197.9)	0.44 (285.0)	0.60 (387.9)	0.79 (506.7)	1.00 (644.7)	1.27 (817.3)
Development length for $f_y = 60$ ksi and $f'_c = 2,500$ psi (normal weight concrete) <sup>3</sup>	$l_d$	ACI 318-11 12.2.3	in. (mm)	12.0 (304.8)	14.4 (365.8)	18.0 (457.2)	21.6 (548.6)	31.5 (800.1)	36.0 (914.4)	40.5 (1028.7)	45.0 (1143)
Development length for $f_y = 60$ ksi and $f'_c = 4,000$ psi (normal weight concrete) <sup>3</sup>	$l_d$	ACI 318-11 12.2.3	in. (mm)	12.0 (304.8)	12.0 (304.8)	14.2 (361.4)	17.1 (433.7)	24.9 (632.5)	28.5 (722.9)	32.0 (812.8)	35.6 (904.2)

For SI: 1 inch = 25.4 mm, 1 lbf = 4.448 N, 1 psi = 0.006897 MPa.

For pound-inch units: 1 mm = 0.03937 inches, 1 N = 0.2248 lbf, 1 MPa = 145.0 psi

<sup>1</sup> Development lengths valid for static, wind, and earthquake loads (SDC A and B).

<sup>2</sup> Development lengths in SDC C through F must comply with ACI 318-11 Chapter 21 and section 4.2.4 of this report. The value of  $f'_c$  used to calculate development lengths shall not exceed 2,500 psi for post-installed reinforcing bar applications in SDCs C, D, E, and F.

<sup>3</sup> For sand-lightweight concrete, increase development length by 33%, unless the provisions of ACI 318-11 12.2.4 (d) are met to permit  $\lambda > 0.75$ .

<sup>4</sup>  $\left(\frac{C_b + K_{tr}}{d_b}\right) = 2.5$ ,  $\psi_t = 1.0$ ,  $\psi_e = 1.0$ ,  $\psi_s = 0.8$  for  $d_b \leq \#6$ , 1.0 for  $d_b > \#6$ .

**TABLE 26—DEVELOPMENT LENGTH FOR EU METRIC REINFORCING BARS IN HOLES DRILLED WITH A HAMMER DRILL AND CARBIDE BIT OR HILTI HOLLOW CARBIDE BIT<sup>1,2,4</sup>**

DESIGN INFORMATION	Symbol	Criteria Section of Reference Standard	Units	Bar size						
				8	10	12	16	20	25	32
Nominal reinforcing bar diameter	$d_b$	BS 4449: 2005	mm (in.)	8 (0.315)	10 (0.394)	12 (0.472)	16 (0.630)	20 (0.787)	25 (0.984)	32 (1.260)
Nominal bar area	$A_b$	BS 4449: 2005	mm <sup>2</sup> (in <sup>2</sup> )	50.3 (0.08)	78.5 (0.12)	113.1 (0.18)	201.1 (0.31)	314.2 (0.49)	490.9 (0.76)	804.2 (1.25)
Development length for $f_y = 72.5$ ksi and $f'_c = 2,500$ psi (normal weight concrete) <sup>3</sup>	$l_d$	ACI 318-11 12.2.3	mm (in.)	305 (12.0)	348 (13.7)	417 (16.4)	556 (21.9)	871 (34.3)	1087 (42.8)	1392 (54.8)
Development length for $f_y = 72.5$ ksi and $f'_c = 4,000$ psi (normal weight concrete) <sup>3</sup>	$l_d$	ACI 318-11 12.2.3	mm (in.)	305 (12.0)	305 (12.0)	330 (13.0)	439 (17.3)	688 (27.1)	859 (33.8)	1100 (43.3)

For SI: 1 inch  $\equiv$  25.4 mm, 1 lbf = 4.448 N, 1 psi = 0.006897 MPa.  
 For pound-inch units: 1 mm = 0.03937 inches, 1 N = 0.2248 lbf, 1 MPa = 145.0 psi

- <sup>1</sup>Development lengths valid for static, wind, and earthquake loads (SDC A and B).
- <sup>2</sup>Development lengths in SDC C through F must comply with ACI 318-11 Chapter 21 and section 4.2.4 of this report. The value of  $f'_c$  used to calculate development lengths shall not exceed 2,500 psi for post-installed reinforcing bar applications in SDCs C, D, E, and F.
- <sup>3</sup>For sand-lightweight concrete, increase development length by 33%, unless the provisions of ACI 318-11 12.2.4 (d) are met to permit  $\lambda > 0.75$ .
- <sup>4</sup> $\left(\frac{c_b + K_{tr}}{d_b}\right) = 2.5$ ,  $\psi_t = 1.0$ ,  $\psi_e = 1.0$ ,  $\psi_s = 0.8$  for  $d_b < 20$ mm, 1.0 for  $d_b \geq 20$ mm.

**TABLE 27—DEVELOPMENT LENGTH FOR CANADIAN METRIC REINFORCING BARS IN HOLES DRILLED WITH A HAMMER DRILL AND CARBIDE BIT OR HILTI HOLLOW CARBIDE BIT<sup>1,2,4</sup>**

DESIGN INFORMATION	Symbol	Criteria Section of Reference Standard	Units	Bar size				
				10M	15M	20M	25M	30M
Nominal reinforcing bar diameter	$d_b$	CAN/CSA-G30.18 Gr. 400	mm (in.)	11.3 (0.445)	16.0 (0.630)	19.5 (0.768)	25.2 (0.992)	29.9 (1.177)
Nominal bar area	$A_b$	CAN/CSA-G30.18 Gr. 400	mm <sup>2</sup> (in <sup>2</sup> )	100.3 (0.16)	201.1 (0.31)	298.6 (0.46)	498.8 (0.77)	702.2 (1.09)
Development length for $f_y = 58$ ksi and $f'_c = 2,500$ psi (normal weight concrete) <sup>3</sup>	$l_d$	ACI 318-11 12.2.3	mm (in.)	315 (12.4)	445 (17.5)	678 (26.7)	876 (34.5)	1041 (41.0)
Development length for $f_y = 58$ ksi and $f'_c = 4,000$ psi (normal weight concrete) <sup>3</sup>	$l_d$	ACI 318-11 12.2.3	mm (in.)	305 (12.0)	353 (13.9)	536 (21.1)	693 (27.3)	823 (32.4)

For SI: 1 inch  $\equiv$  25.4 mm, 1 lbf = 4.448 N, 1 psi = 0.006897 MPa.  
 For pound-inch units: 1 mm = 0.03937 inches, 1 N = 0.2248 lbf, 1 MPa = 145.0 psi

- <sup>1</sup>Development lengths valid for static, wind, and earthquake loads (SDC A and B).
- <sup>2</sup>Development lengths in SDC C through F must comply with ACI 318-11 Chapter 21 and section 4.2.4 of this report. The value of  $f'_c$  used to calculate development lengths shall not exceed 2,500 psi for post-installed reinforcing bar applications in SDCs C, D, E, and F.
- <sup>3</sup>For sand-lightweight concrete, increase development length by 33%, unless the provisions of ACI 318-11 12.2.4 (d) are met to permit  $\lambda > 0.75$ .
- <sup>4</sup> $\left(\frac{c_b + K_{tr}}{d_b}\right) = 2.5$ ,  $\psi_t = 1.0$ ,  $\psi_e = 1.0$ ,  $\psi_s = 0.8$  for  $d_b < 20$ M, 1.0 for  $d_b \geq 20$ M.

**Specifications / Assumptions:**

ASTM A193 Grade B7 threaded rod  
 Normal weight concrete,  $f'_c = 4,000$  psi  
 Seismic Design Category (SDC) B  
 No supplementary reinforcing in accordance with ACI 318-11 D.1 will be provided.  
 Assume maximum short term (diurnal) base material temperature  $\leq 130^\circ$  F.  
 Assume maximum long term base material temperature  $\leq 110^\circ$  F.  
 Assume installation in dry concrete and hammer-drilled holes.  
 Assume concrete will remain uncracked for service life of anchorage.

**Dimensional Parameters:**

$h_{ef} = 9.0$  in.  
 $s = 4.0$  in.  
 $c_{a,min} = 2.5$  in.  
 $h = 12.0$  in.  
 $d = 1/2$  in.

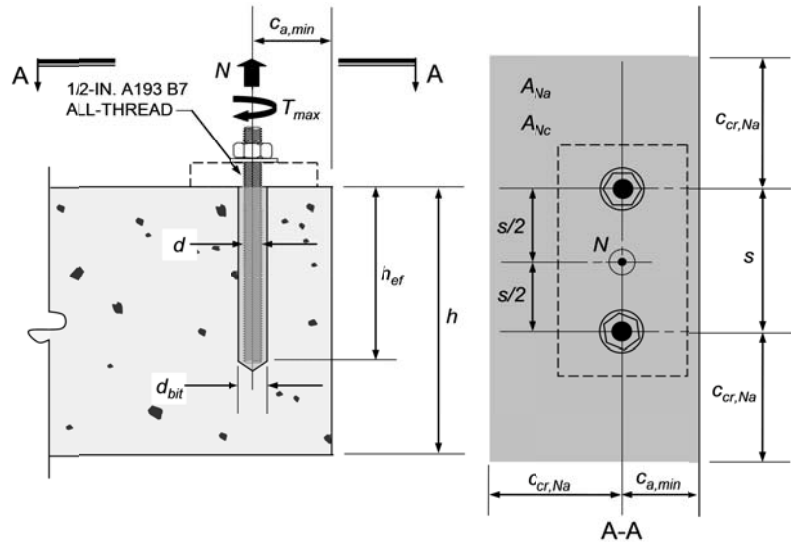

Calculation for the 2012, 2009 and 2006 IBC in accordance with ACI 318-11 Appendix D and this report	ACI 318-11 Code Ref.	Report Ref.
<p><b>Step 1. Check minimum edge distance, anchor spacing and member thickness:</b></p> <p><math>c_{min} = 2.5</math> in. <math>\leq c_{a,min} = 2.5</math> in. <math>\therefore</math> OK  <math>s_{min} = 2.5</math> in. <math>\leq s = 4.0</math> in. <math>\therefore</math> OK  <math>h_{min} = h_{ef} + 1.25</math> in. <math>= 9.0 + 1.25 = 10.25</math> in. <math>\leq h = 12.0</math> <math>\therefore</math> OK  <math>h_{ef,min} \leq h_{ef} \leq h_{ef,max} = 2.75</math> in. <math>\leq 9</math> in. <math>\leq 10</math> in. <math>\therefore</math> OK</p>	-	Table 12 Table 14
<p><b>Step 2. Check steel strength in tension:</b></p> <p>Single Anchor: <math>N_{sa} = A_{se} \cdot f_{uta} = 0.1419</math> in<sup>2</sup> <math>\cdot 125,000</math> psi <math>= 17,738</math> lb.                      Anchor Group: <math>\phi N_{sa} = \phi \cdot n \cdot A_{se} \cdot f_{uta} = 0.75 \cdot 2 \cdot 17,738</math> lb. <math>= 26,606</math> lb.                      Or using Table 11: <math>\phi N_{sa} = 0.75 \cdot 2 \cdot 17,735</math> lb. <math>= 26,603</math> lb.</p>	D.5.1.2 Eq. (D-2)	Table 3 Table 11
<p><b>Step 3. Check concrete breakout strength in tension:</b></p> <p><math>N_{cbg} = \frac{A_{Nc}}{A_{Nc0}} \cdot \psi_{ec,N} \cdot \psi_{ed,N} \cdot \psi_{c,N} \cdot \psi_{cp,N} \cdot N_b</math></p>	D.5.2.1 Eq. (D-4)	-
<p><math>A_{Nc} = (3 \cdot h_{ef} + s)(1.5 \cdot h_{ef} + c_{a,min}) = (3 \cdot 9 + 4)(13.5 + 2.5) = 496</math> in<sup>2</sup></p>	-	-
<p><math>A_{Nc0} = 9 \cdot h_{ef}^2 = 729</math> in<sup>2</sup></p>	D.5.2.1 and Eq. (D-5)	-
<p><math>\psi_{ec,N} = 1.0</math> no eccentricity of tension load with respect to tension-loaded anchors</p>	D.5.2.4	-
<p><math>\psi_{ed,N} = 0.7 + 0.3 \cdot \frac{c_{a,min}}{1.5h_{ef}} = 0.7 + 0.3 \cdot \frac{2.5}{1.5 \cdot 9} = 0.76</math></p>	D.5.2.5 and Eq. (D-10)	-
<p><math>\psi_{c,N} = 1.0</math> uncracked concrete assumed (<math>k_{c,uncr} = 24</math>)</p>	D.5.2.6	Table 12
<p>Determine <math>c_{ac}</math>:</p> <p>From Table 14: <math>\tau_{uncr} = 1,670</math> psi</p> <p><math>\tau_{uncr} = \frac{k_{c,uncr}}{\pi \cdot d} \sqrt{h_{ef} \cdot f'_c} = \frac{24}{\pi \cdot 0.5} \sqrt{9.0 \cdot 4,000} = 2,899</math> psi <math>&gt; 1,670</math> psi <math>\therefore</math> use 1,670 psi</p> <p><math>c_{ac} = h_{ef} \cdot \left( \frac{\tau_{uncr}}{1,160} \right)^{0.4} \cdot \left[ 3.1 - 0.7 \cdot \frac{h}{h_{ef}} \right] = 9 \cdot \left( \frac{1,670}{1,160} \right)^{0.4} \cdot \left[ 3.1 - 0.7 \cdot \frac{12}{9} \right] = 22.6</math> in.</p>	-	Section 4.1.10 Table 14
<p>For <math>c_{a,min} &lt; c_{ac}</math> <math>\psi_{cp,N} = \frac{\max\{c_{a,min}; 1.5 \cdot h_{ef}\}}{c_{ac}} = \frac{\max\{2.5; 1.5 \cdot 9\}}{22.6} = 0.60</math></p>	D.5.2.7 and Eq. (D-12)	-
<p><math>N_b = k_{c,uncr} \cdot \lambda \cdot \sqrt{f'_c} \cdot h_{ef}^{1.5} = 24 \cdot 1.0 \cdot \sqrt{4,000} \cdot 9^{1.5} = 40,983</math> lb.</p>	D.5.2.2 and Eq. (D-6)	Table 12
<p><math>N_{cbg} = \frac{496}{729} \cdot 1.0 \cdot 0.76 \cdot 1.0 \cdot 0.60 \cdot 40,983 = 12,715</math> lb.</p>	-	-
<p><math>\phi N_{cbg} = 0.65 \cdot 12,715 = 8,265</math> lb.</p>	D.4.3(c)	Table 12

FIGURE 7—SAMPLE CALCULATION [POST-INSTALLED ANCHORS]

<p><b>Step 4. Check bond strength in tension:</b></p> $N_{ag} = \frac{A_{Na}}{A_{Na0}} \cdot \psi_{ec,Na} \cdot \psi_{ed,Na} \cdot \psi_{cp,Na} \cdot N_{ba}$	<p><b>D.5.5.1 Eq. (D-19)</b></p>	<p>-</p>
$A_{Na} = (2C_{Na} + s)(C_{Na} + C_{a,min})$ $C_{Na} = 10d_a \sqrt{\frac{\tau_{uncr}}{1,100}} = 10 \cdot 0.5 \cdot \sqrt{\frac{1,670}{1,100}} = 6.16 \text{ in.}$ $A_{Na} = (2 \cdot 6.16 + 4)(6.16 + 2.5) = 141.3 \text{ in}^2$	<p><b>D.5.5.1 Eq. (D-21)</b></p>	<p><b>Table 14</b></p>
$A_{Na0} = (2C_{Na})^2 = (2 \cdot 6.16)^2 = 151.8 \text{ in}^2$	<p><b>D.5.5.1 and Eq. (D-20)</b></p>	<p>-</p>
<p><math>\psi_{ec,Na} = 1.0</math> no eccentricity – loading is concentric</p>	<p><b>D.5.5.3</b></p>	<p>-</p>
$\psi_{ed,Na} = \left( 0.7 + 0.3 \cdot \frac{c_{a,min}}{c_{Na}} \right) = \left( 0.7 + 0.3 \cdot \frac{2.5}{6.16} \right) = 0.82$	<p><b>D5.5.4</b></p>	<p>-</p>
$\psi_{cp,Na} = \frac{\max\{c_{a,min}; c_{Na}\}}{c_{ac}} = \frac{\max\{2.5; 6.16\}}{22.6} = 0.27$	<p><b>D.5.5.5</b></p>	<p>-</p>
$N_{ba} = \lambda \cdot \tau_{uncr} \cdot \pi \cdot d \cdot h_{ef} = 1.0 \cdot 1,670 \cdot \pi \cdot 0.5 \cdot 9.0 = 23,609 \text{ lb.}$	<p><b>D.5.5.2 and Eq. (D-22)</b></p>	<p><b>Table 14</b></p>
$N_{ag} = \frac{141.3}{151.8} \cdot 1.0 \cdot 0.82 \cdot 0.27 \cdot 23,609 = 4,865 \text{ lb.}$	<p>-</p>	<p>-</p>
<p><math>\phi N_{ag} = 0.65 \cdot 4,865 = 3,163 \text{ lb.}</math></p>	<p><b>D.4.3(c)</b></p>	<p><b>Table 14</b></p>
<p><b>Step 5. Determine controlling strength:</b></p> <p>Steel Strength <math>\phi N_{sa} = 26,603 \text{ lb.}</math></p> <p>Concrete Breakout Strength <math>\phi N_{cbg} = 8,265 \text{ lb.}</math></p> <p>Bond Strength <math>\phi N_{ag} = 3,163 \text{ lb. CONTROLS}</math></p>	<p><b>D.4.1</b></p>	<p>-</p>

FIGURE 7—SAMPLE CALCULATION [POST-INSTALLED ANCHORS] (Continued)

**Specifications / Assumptions:**

**Development length for column starter bars**

Existing construction (E):

Foundation grade beam 24 wide x 36-in deep., 4 ksi normal weight concrete, ASTM A615 Gr. 60 reinforcement

New construction (N):

18 x 18-in. column as shown, centered on 24-in wide grade beam, 4 ksi normal weight concrete, ASTM A615 Gr. 60 reinforcement, 4 - #7 column bars

The column must resist moment and shear arising from wind loading.

**Dimensional Parameters:**

$$d_b = 0.875 \text{ in.}$$

$$\left( \frac{c_b + K_{tr}}{d_b} \right) = 2.5$$

$$\psi_t = 1.0$$

$$\psi_e = 1.0$$

$$\psi_s = 1.0$$

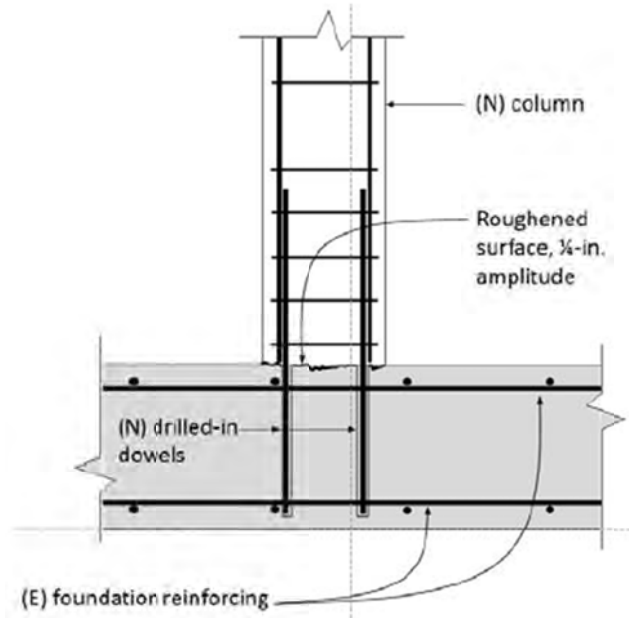

Calculation in accordance with ACI 318-11	ACI 318-11 Code Ref.
<p><b>Step 1. Determination of development length for the column bars:</b></p> $l_d = \left[ \frac{3}{40} \cdot \frac{f_y}{\lambda \cdot \sqrt{f'_c}} \cdot \frac{\psi_t \psi_e \psi_s}{c_b + K_{tr}} \right] \cdot d_b = \left[ \frac{3}{40} \cdot \frac{60000}{1.0 \cdot \sqrt{4000}} \cdot \frac{(1.0)(1.0)(1.0)}{2.5} \right] \cdot 0.875 = 25 \text{ in.}$ <p>Note that the confinement term <math>K_{tr}</math> is taken equal to the maximum value 2.5 given the edge distance and confinement condition</p>	<p>Eq. (12-1)</p>
<p><b>Step 2 Detailing (not to scale)</b></p>	

FIGURE 8—SAMPLE CALCULATION [POST-INSTALLED REINFORCING BARS]

**HILTI**

**Hilti HIT-HY 200-A**  
**Hilti HIT-HY 200-R**

Instruction for use en

**Warning** (A, B) (B)

**Contains:** hydroxypropylmethacrylate, (A) dibenzoyl peroxide (B)

May cause an allergic skin reaction. (A, B)  
Causes serious eye irritation. (B)  
Very toxic to aquatic life. (B)

**ICC ESR 3187**

**Hilti HIT-HY 200-A / -R**

**#1** Dry concrete      Water saturated concrete      Waterfilled borehole in concrete

**#2** HIT-Z  
HIT-Z-R      Threaded rod  
Threaded sleeve      Rebar

**#3** Uncracked concrete      Cracked concrete      Hammer drilling      Hollow drill bit      Diamond coring

**#4** Temperature of concrete      cartridge temperature      Working time      Curing time

**Hilti HIT-HY 200-A / -R**

Ø	HAS HIT-V	HIS-N	Rebar	HIT-Z	HIT-RB	HIT-SZ	HIT-DL	HIT-OHC
d <sub>0</sub> [inch]			d [inch]		[inch]	[inch]	[inch]	Art. No.
7/16	3/8	-	-	3/8	7/16	-	-	387551
1/2	-	-	#3	1/2	1/2	1/2	-	
9/16	1/2	-	10M	1/2	9/16	9/16	9/16	
5/8	-	-	#4	5/8	5/8	5/8	9/16	
11/16	-	3/8	-	11/16	11/16	11/16	11/16	
3/4	5/8	-	15M #5	5/8	3/4	3/4	3/4	
7/8	3/4	1/2	#6	3/4	7/8	7/8	7/8	387552
1	7/8	-	20M #6 #7	-	1	1	1	
1 1/8	1	5/8	#7 #8	-	1 1/8	1 1/8	1	
1 1/4	-	3/4	25M #8	-	1 1/4	1 1/4	1	
1 3/8	1 1/4	-	#9	-	1 3/8	1 3/8	1 3/8	
1 1/2	-	-	30M #10	-	1 1/2	1 1/2	1 3/8	

HIT-DL: h<sub>ef</sub> > 10"      HIT-RB: h<sub>ef</sub> > 20c

Hilti VC	HIT-RE-M	HIT-OHW
Art. No.	Art. No.	Art. No.
Hilti VC	HDM 330 HDM 500 HDE 500-A18	387550

Ø	h <sub>ef</sub>	Art. No. 381215	≥ 6 bar/90 psi @ 6 m³/h
d <sub>0</sub> [inch]	[inch]	Art. No. 381215	≥ 6 bar/90 psi @ 6 m³/h
7/16" - 1 1/8"	2 3/8" - 20"	✓	≥ 6 bar/90 psi @ 6 m³/h
1 1/4" - 1 1/2"	4" - 25"	-	≥ 140 m³/h / ≥ 82 CFM

**Hilti HIT-HY 200-A / -R**

Ø	HIT-V	HIS-N	Rebar	HIT-Z	HIT-RB	HIT-SZ	HIT-DL	HIT-OHC
d <sub>0</sub> [mm]			d [mm]		[mm]	[mm]		Art. No.
10	8	-	-	8	10	-	-	387551
12	10	-	8	10	12	12	12	
14	12	8	10	12	14	14	14	
16	-	-	12	-	16	16	16	
18	16	10	14	16	18	18	18	
20	-	-	15	-	20	20	20	
22	20	12	18	20	22	22	20	387552
25	-	-	20	-	25	25	25	
28	24	16	22	-	28	28	25	
30	27	-	-	-	30	30	25	
32	-	20	24/25	-	32	32	32	
35	30	-	26/28	-	35	35	32	
37	-	-	30	-	37	37	32	
40	-	-	32	-	40	40	32	

HIT-DL: h<sub>ef</sub> > 250 mm      HIT-RB: h<sub>ef</sub> > 20d

Hilti VC	HIT-RE-M	HIT-OHW
Art. No.	Art. No.	Art. No.
Hilti VC	HDM 330 / 500 HDE 500-A18	387550

Ø	h <sub>ef</sub>	Art. No. 381215	≥ 6 bar/90 psi
d <sub>0</sub> [mm]	[mm]	Art. No. 381215	≥ 6 bar/90 psi
10...32	60...500	✓	≥ 6 bar/90 psi
35...40	100...640	-	≥ 140 m³/h

FIGURE 9—MANUFACTURER'S PRINTED INSTALLATION INSTRUCTIONS (MPII)

**Hilti HIT-HY 200-A / -R**

HIT-HY 200-A							
		HIT-V, HAS Rebar			HIT-Z		
		HIS-N Rebar					
		Rebar					
[°C]	[°F]	t <sub>work</sub>	t <sub>cure</sub>	t <sub>work</sub>	t <sub>cure</sub>	t <sub>work</sub>	t <sub>cure</sub>
-10...-5	14...23	1,5 h	7 t	-	-	-	-
-4...0	24...32	50 min	4 t	-	-	-	-
1...5	33...41	25 min	2 t	-	-	-	-
6...10	42...50	15 min	75 min	15 min	75 min	15 min	75 min
11...20	51...68	7 min	45 min	7 min	45 min	7 min	45 min
21...30	69...86	4 min	30 min	4 min	30 min	4 min	30 min
31...40	87...104	3 min	30 min	3 min	30 min	3 min	30 min

HIT-HY 200-R							
		HIT-V, HAS Rebar			HIT-Z		
		HIS-N Rebar					
		Rebar					
[°C]	[°F]	t <sub>work</sub>	t <sub>cure</sub>	t <sub>work</sub>	t <sub>cure</sub>	t <sub>work</sub>	t <sub>cure</sub>
-10...-5	14...23	3 h	20 t	-	-	-	-
-4...0	24...32	2 h	8 t	-	-	-	-
1...5	33...41	1 h	4 t	-	-	-	-
6...10	42...50	40 min	2,5 t	40 min	2,5 h	40 min	2,5 h
11...20	51...68	15 min	1,5 t	15 min	1,5 h	15 min	1,5 h
21...30	69...86	9 min	1 t	9 min	1 h	9 min	1 h
31...40	87...104	6 min	1 t	6 min	1 h	6 min	1 h

Rebar hef ≥ 20d

HIT-HY 200-A HIT-HY 200-R	HDM, HDE	Rebar	h <sub>ef</sub>	14°F...104°F -10°C...40°C	50°F...86°F 10°C...30°C
HIT-HY 200-A HIT-HY 200-R	HDE	≤ US #5	12 1/2 ... 37 1/2 [inch] 320 ... 960 [mm]	14°F...104°F -10°C...40°C	50°F...86°F 10°C...30°C
		≤ EU 16mm	320 ... 960 [mm]	14°F...104°F -10°C...40°C	32°F...86°F 0°C...30°C
		≤ CAN 15M	320 ... 960 [mm]	14°F...104°F -10°C...40°C	32°F...86°F 0°C...30°C
HIT-HY 200-R	HDE	≤ US #8	20 ... 60 [inch]	32°F...104°F 0°C...40°C	32°F...86°F 0°C...30°C
		≤ EU 25mm	500 ... 1500 [mm]	32°F...104°F 0°C...40°C	32°F...86°F 0°C...30°C
		≤ CAN 25M	504 ... 1512 [mm]	32°F...104°F 0°C...40°C	32°F...86°F 0°C...30°C
HIT-HY 200-R	HDE	≤ US #10	25 ... 75 [inch]	50°F...86°F 10°C...30°C	50°F...86°F 10°C...20°C
		≤ EU 32mm	640 ... 1920 [mm]	50°F...86°F 10°C...30°C	50°F...86°F 10°C...20°C
		≤ CAN 30M	598 ... 1794 [mm]	50°F...86°F 10°C...30°C	50°F...86°F 10°C...20°C

HIT-HY 200-A HIT-HY 200-R	HDM, HDE	Rebar	h <sub>ef</sub>	14°F...104°F -10°C...40°C	50°F...86°F 10°C...30°C
HIT-HY 200-A HIT-HY 200-R	HDE	≤ US #5	12 1/2 ... 37 1/2 [inch] 320 ... 960 [mm]	14°F...104°F -10°C...40°C	50°F...86°F 10°C...30°C
		≤ EU 16mm	320 ... 960 [mm]	14°F...104°F -10°C...40°C	32°F...86°F 0°C...30°C
		≤ CAN 15M	320 ... 960 [mm]	14°F...104°F -10°C...40°C	32°F...86°F 0°C...30°C

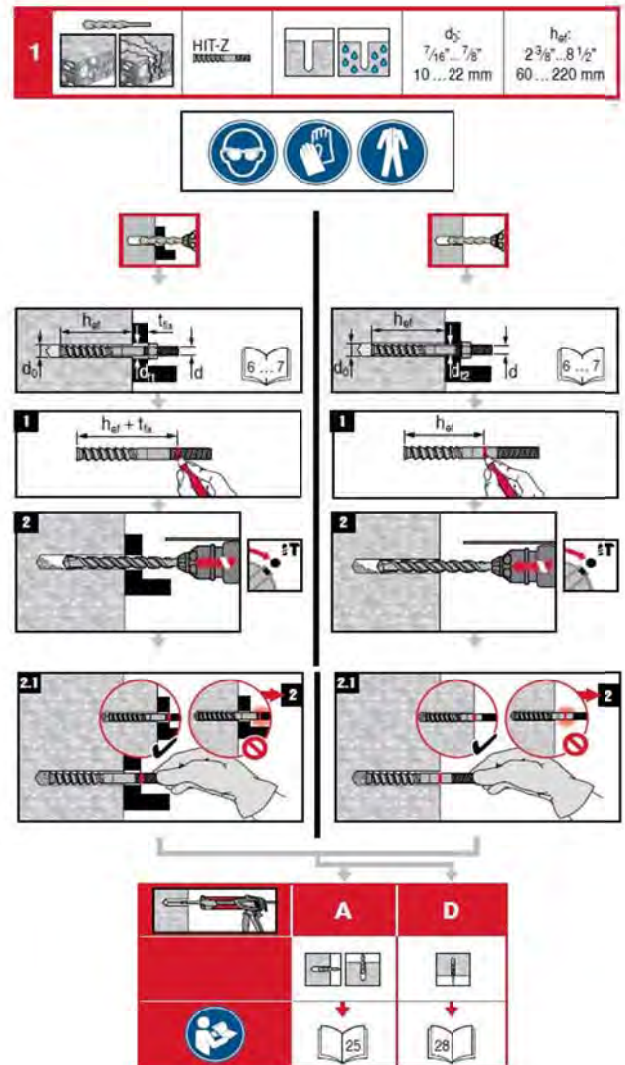



FIGURE 9—MANUFACTURER’S PRINTED INSTALLATION INSTRUCTIONS (MPII) (Continued)

**2**

HIT-Z



$d_0$ :  $7/8" \dots 7/8"$   
10...22 mm

$h_{ef}$ :  $2 3/8" \dots 8 1/4"$   
60...220 mm

**3**

HIT-Z  
HAS/HIT-V  
HIS-N  
Rebar



$d_0$ :  $1/2" \dots 1 1/8"$   
12...32 mm

$h_{ef}$ :  $2 3/8" \dots 39 3/8"$   
60...1000 mm

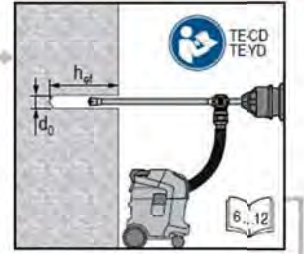
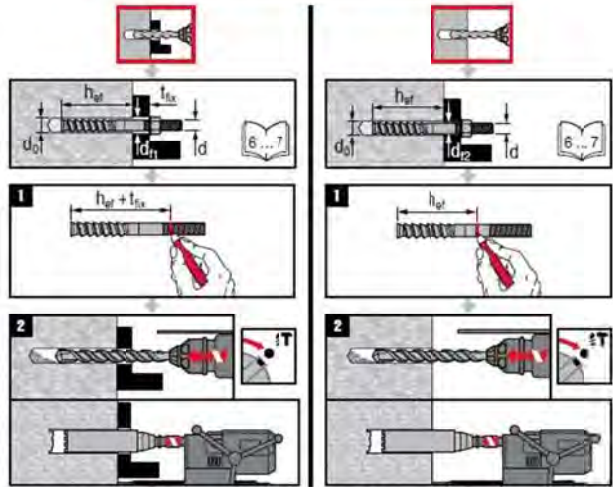

	B	C	D
$h_{ef}$	$2 3/8" \dots 9 7/8"$ 60...250 mm	$2 3/8" \dots 75 1/2"$ 60...1920 mm	$2 3/8" \dots 75 1/2"$ 60...1920 mm
	26	27	28

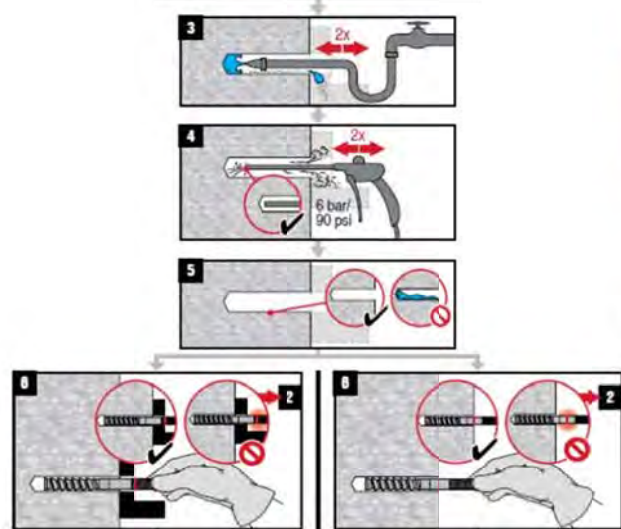

**4**

HIT-V  
HAS  
HIS-N  
Rebar



$d_0$ :  $7/16" \dots 1 1/2"$   
10...40 mm

$h_{ef}$ :  $2 3/8" \dots 75 1/2"$   
60...1920 mm

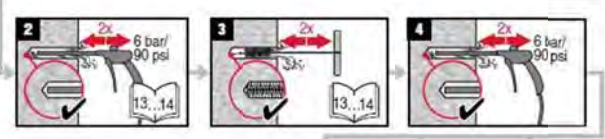
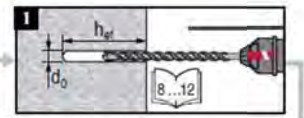

	B	D
$h_{ef}$	$2 3/8" \dots 9 7/8"$ 60...250 mm	$2 3/8" \dots 75 1/2"$ 60...1920 mm
	26	28

	B	C	D
$h_{ef}$	$2 3/8" \dots 9 7/8"$ 60...250 mm	$2 3/8" \dots 75 1/2"$ 60...1920 mm	$2 3/8" \dots 75 1/2"$ 60...1920 mm
	26	27	28

FIGURE 9—MANUFACTURER'S PRINTED INSTALLATION INSTRUCTIONS (MPII) (Continued)



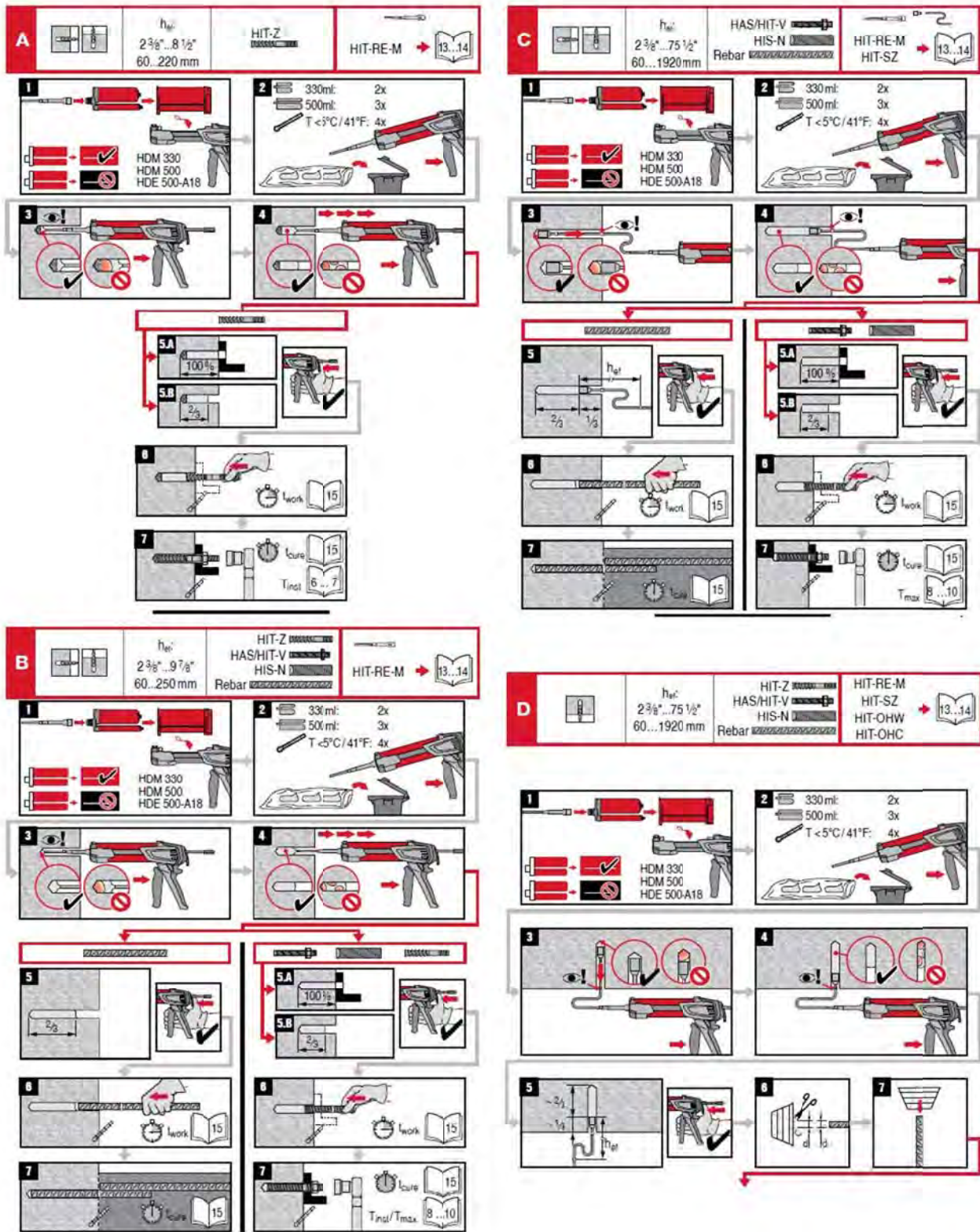
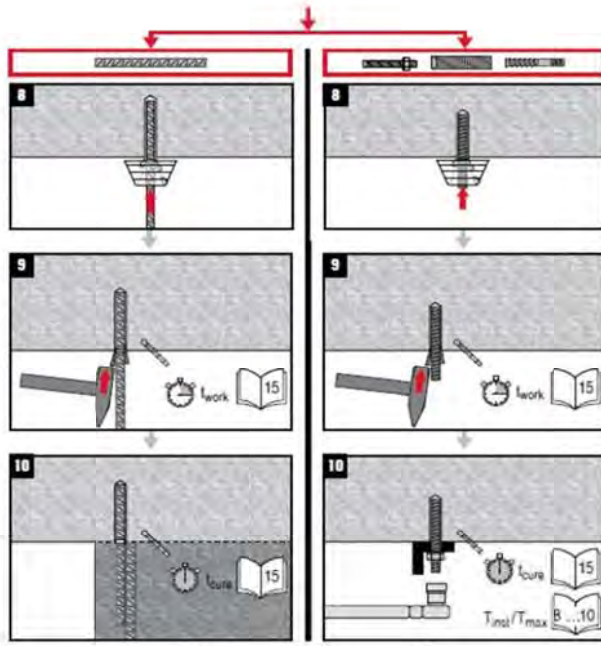

FIGURE 9—MANUFACTURER'S PRINTED INSTALLATION INSTRUCTIONS (MPII) (Continued)



Hilti HIT-HY 200-A / -R

Product Information

- Always keep these instructions together with the product even when given to other persons.
- **Material Safety Data Sheet:** Review the MSDS before use.
- **Check expiration date:** See imprint on foil pack manifold (month/year). Do not use expired product.
- **Foil pack temperature during usage:** 0 °C to 40 °C / 32 °F to 104 °F.
- **Base material temperature at time of installation:**  
 BAS/HIT-V, HIS, Rebar: between -10 °C and 40 °C / 14 °F and 104 °F.  
 HIT-Z: between +5°C and 40°C / 41°F and 104°F.
- **Conditions for transport and storage:** Keep in a cool, dry and dark place between 5 °C and 25 °C / 41 °F and 77 °F.
- For any application not covered by this document / beyond values specified, please contact Hilti.
- **Partly used foil packs must remain in the cassette** and has to be used within **4 weeks**. Leave the mixer attached on the foil pack manifold and store within the cassette under the recommended storage conditions. If reused, attach a new mixer and discard the initial quantity of anchor adhesive.

NOTICE

- ▲ **The surface of the HIT-Z anchor rod must not be altered in any way.**
- ▲ **Improper handling may cause mortar splashes.**
  - Always wear safety glasses, gloves and protective clothes during installation.
  - Never start dispensing without a mixer properly screwed on.
  - Attach a new mixer prior to dispensing a new foil pack (ensure snug fit).
  - Use only the type of mixer (HIT-RE-M) supplied with the adhesive. Do not modify the mixer in any way.
  - Never use damaged foil packs and/or damaged or unclear foil pack holders (cassettes).
- ▲ **Poor load values / potential failure of fastening points due to inadequate borehole cleaning.**
  - The boreholes must be free of debris, dust, water, ice, oil, grease and other contaminants prior to adhesive injection.
  - For blowing out the borehole - blow out with oil free air until return air stream is free of noticeable dust.
  - For flushing the borehole - flush with water line pressure until water runs clear.
  - For brushing the borehole - only use specified wire brush. The brush must resist insertion into the borehole - if not the brush is too small and must be replaced.
- ▲ **Ensure that boreholes are filled from the back of the borehole without forming air voids.**
  - If necessary use the accessories / extensions to reach the back of the borehole.
  - For overhead applications use the overhead accessories HIT-SZ and take special care when inserting the fastening element. Excess adhesive may be forced out of the borehole. Make sure that no mortar drips onto the installer.
- ▲ **Not adhering to these setting instructions can result in failure of fastening points!**

Hilti HIT-HY 210-A / -R

Adhesive anchoring system for rebar and anchor fastenings in concrete.

**Hilti HIT-HY 210-A**  
 Contains: Hydroxypropylmethacrylat (A), Dibenzoylperoxid (B)

**Warning**

H317	May cause an allergic skin reaction. (A, B)
H319	Causes serious eye irritation. (B)
H400	Very toxic to aquatic life. (B)
P262	Do not get in eyes, on skin or on clothing.
P280	Wear protective gloves/protective clothing/eye protection/face protection.
P302 - P352	IF ON SKIN: Wash with plenty of soap and water.
P305 + P351 - P338	IF IN EYES: Rinse cautiously with water for several minutes. Remove contact lenses, if present and easy to do. Continue rinsing.
P333+313	If skin irritation or rash occurs: Get medical advice/attention.
P37+313	If eye irritation persists: Get medical advice/attention.

Disposal considerations

Empty packs:

- Leave the mixer attached and dispose of via the local Green Dot recovery system
- or EAK waste material code: 150102 plastic packaging

Full or partially emptied packs:

- Must be disposed of as special waste in accordance with official regulations.
  - EAK waste material code: 08 04 09\* waste adhesives and sealants containing organic solvents or other dangerous substances.
  - or EAK waste material code: 20 01 27\* paint, inks, adhesives and resins containing dangerous substances.

**Content:** 330ml / 11.1 fl.oz. 500 ml / 16.9 fl.oz. **Weight:** 590 g / 20.8 oz 890 g / 31.4 oz

Failure to observe these installation instructions, use of non-Hilti anchors, poor or questionable base material conditions, or unique applications may affect the reliability or performance of the fastenings.

FIGURE 9—MANUFACTURER’S PRINTED INSTALLATION INSTRUCTIONS (MPII) (Continued)

**ICC-ES Evaluation Report****ESR-3187 FBC Supplement\***

Reissued March 2014

This report is subject to renewal March 2016.

[www.icc-es.org](http://www.icc-es.org) | (800) 423-6587 | (562) 699-0543

A Subsidiary of the International Code Council®

**DIVISION: 03 00 00—CONCRETE**  
**Section: 03 16 00—Concrete Anchors****DIVISION: 05 00 00—METALS**  
**Section: 05 05 19—Post-Installed Concrete Anchors****REPORT HOLDER:****HILTI, INC.**  
7250 DALLAS PARKWAY, SUITE 1000  
PLANO, TEXAS 75024 (800) 879-8000  
[www.us.hilti.com](http://www.us.hilti.com)  
[HiltiTechEng@us.hilti.com](mailto:HiltiTechEng@us.hilti.com)**EVALUATION SUBJECT:****HILTI HIT-HY 200 ADHESIVE ANCHORS AND POST INSTALLED REINFORCING BARS IN CONCRETE****1.0 REPORT PURPOSE AND SCOPE****Purpose:**

The purpose of this evaluation report supplement is to indicate that the Hilti HIT-HY 200 Adhesive Anchors and Post-Installed Reinforcing Bar System in Concrete, recognized in ICC-ES master evaluation report ESR-3187, has also been evaluated for compliance with the codes noted below.

**Applicable code editions:**

- 2014 and 2010 *Florida Building Code—Building*
- 2014 and 2010 *Florida Building Code—Residential*

**2.0 CONCLUSIONS**

The Hilti HIT-HY 200 Adhesive Anchor System and Post-Installed Reinforcing Bar System, described in Sections 2.0 through 7.0 of the master evaluation report ESR-3187, comply with the 2014 and 2010 *Florida Building Code—Building* and the 2014 and 2010 *Florida Building Code—Residential*, provided the design and installation are in accordance with the *International Building Code*® provisions noted in the master report, and under the following conditions:

- Design wind loads must be based on Section 1609 of the 2014 and 2010 *Florida Building Code—Building* or Section R301.2.1.1 of the 2014 and 2010 *Florida Building Code—Residential*, as applicable.
- Load combinations must be in accordance with Section 1605.2 or Section 1605.3 of the 2014 and 2010 *Florida Building Code—Building*, as applicable.

Use of the Hilti HIT-HY 200 Adhesive Anchor System and Post-Installed Reinforcing Bar System with stainless steel threaded rod materials and reinforcing bars, stainless steel Hilti HIT-Z-R anchor rods, and stainless steel Hilti HIS-RN inserts has also been found to be in compliance with the High-Velocity Hurricane Zone provisions of the 2014 and 2010 *Florida Building Code—Building* and the 2014 and 2010 *Florida Building Code—Residential*, when the following condition is met:

The design wind loads for use of the anchors in a High-Velocity Hurricane Zone are based on Section 1620 of the *Florida Building Code—Building*.

Use of the Hilti HIT-HY 200 Adhesive Anchor System and Post-Installed Reinforcing Bar System with carbon steel threaded rod materials and reinforcing bars, carbon steel Hilti HIT-Z anchor rods and carbon steel Hilti HIS-N inserts for compliance with the High-velocity Hurricane Zone provisions of the 2014 and 2010 *Florida Building Code—Building* and the 2014 and 2010 *Florida Building Code—Residential* has not been evaluated and is outside the scope of this supplemental report.

For products falling under Florida Rule 9N-3, verification that the report holder's quality-assurance program is audited by a quality-assurance entity approved by the Florida Building Commission for the type of inspections being conducted is the responsibility of an approved validation entity (or the code official, when the report holder does not possess an approval by the Commission).

This supplement expires concurrently with the master report, reissued March 2014 and revised July 2015.

**\*Revised July 2015**